



Ford F-150 (P702 14th Gen) Predator & Toro Front Bar Fitting Instruction

IMPORTANT! – READ BEFORE INSTALLATION

- When installed in accordance with these instructions, the front protection bar does not affect the operation of the vehicles SRS airbags.
- This product must be installed exactly as per these instructions using only hardware supplied.
- Take a few moments to read instructions thoroughly before beginning work.
- In the event of damage to any bar component please contact OFFROAD ANIMAL to arrange repair/replacement of components.
- Do not use this product for any vehicle make or model other than that specified on these instructions.
- Do not remove labels from this product.
- This product and its fixings must not be modified in any way unless stated in these fitting instructions.
- The installation of this product is recommended for trained personnel.
- These instructions are correct at time of publication. OFFROAD ANIMAL cannot be held responsible for the impact of any changes subsequently made by the vehicle manufacturer. If you find something has changed, please contact us to let us know!
- During installation it is the duty of the installer to check correct operation/clearances of all components.
- If Instructions are to be printed for reference in the workshop, it is recommended that they are printed in colour, for best legibility.

GENERAL CARE AND MAINTENANCE

Use caution when cleaning with pressure washers, as they may compromise the product coating's integrity. Exercise care to avoid surface damage.

Only wash the product with a PH neutral car wash to prevent paint damage and discolouration.

Do not use acidic or alkaline based cleaning products.

Plastic parts may be maintained with silicone spray.

It is important to perform regular checks (pre/during/post trip or on an annual basis) on the installed product. More frequent checks may be required in extreme use cases. Checks include:

- Visual inspection for damage (eg. cracks, chips, dents etc.)
- Electrical wiring is not rubbing anything or worn out
- Bolts are torqued to correct specification (see torque guide below)

For touching up small stone chips, Offroad Animal recommends the following paint products:

- Dupli-Color Trim & Bumper Paint Black (TB101)
- VHT Hood, Bumper & Trim Paint Black (SP27)

BOLT TORQUE SETTINGS

Use the following bolt torques on all general fasteners, unless otherwise specified.

GENERAL FASTENERS	
Size	Torque Nm
M5	5 Nm
M6	9 Nm
M8	22 Nm
M10	44 Nm
M12	77 Nm

Use the following bolt torques on all structural front bar mount and tow point fasteners, and rear towbar fasteners, unless otherwise specified.

FRONT BAR MOUNTS AND TOW POINTS + REAR TOWBAR	
Size	Torque Nm
M10	57 Nm
M12	100 Nm
M14	164 Nm
M16	248 Nm

Always use a torque wrench to set correct torque settings. Ensure torque wrench is set to Nm unit of measurement. Otherwise perform conversion to lb-ft.

PARTS LISTING

IMPORTANT: Check all parts are present before beginning work! Contact OFFROAD ANIMAL if something is missing.



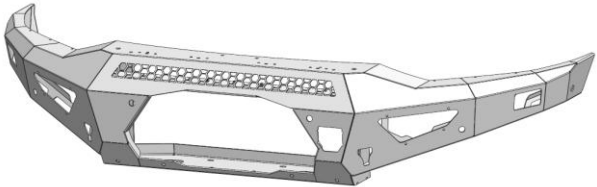
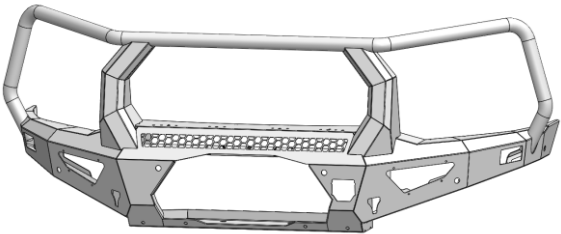
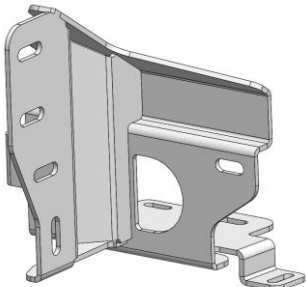
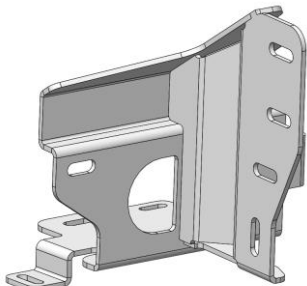

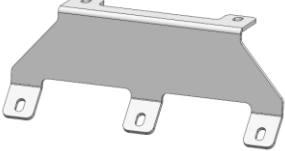
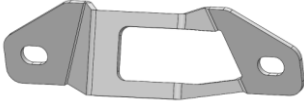
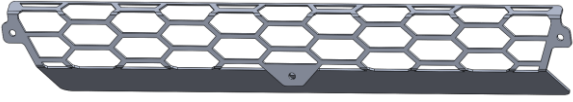
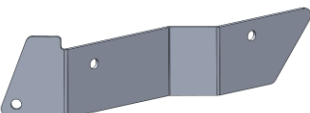

Parts List



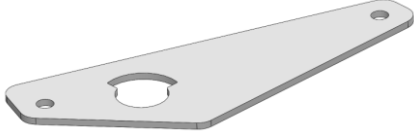
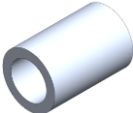
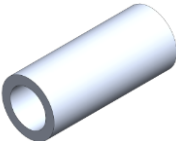

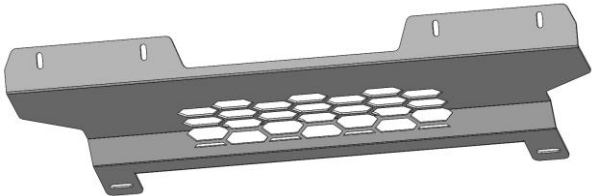

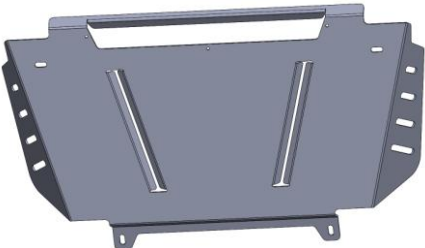
Qty	Part Number	Description	Image
PREDATOR ONLY			
1	FB-F150-P702-21-PR-ASM1	P702 F-150 Predator Bar Welded Assembly	
TORO ONLY			
1	FB-F150-P702-21-TOR-ASM1	P702 F-150 Predator Bar Welded Assembly	
1	FB-F150-P702-21-PR-ASM2R	P702 F-150 Impact Assy RH	
1	FB-F150-P702-21-PR-ASM2L	P702 F-150 Impact Assy LH	

<p>1</p>	<p>FB-F150-P702-21-PR-ASM3R</p>	<p>P702 F-150 Chassis Brace RH</p>	
<p>1</p>	<p>FB-F150-P702-21-PR-ASM3L</p>	<p>P702 F-150 Chassis Brace LH</p>	
<p>1</p>	<p>FB-F150-P702-21-PR-ASM4</p>	<p>P702 F-150 Mesh Fairlead Assy</p>	
<p>2</p>	<p>FB-F150-P702-21-PR-ASM5</p>	<p>P702 F-150 Tow Hook Nut Plate</p>	
<p>1</p>	<p>FB-F150-P702-21-PR-ASM6R</p>	<p>P702 F-150 Lower Base Plate Mount Welded Assy RH</p>	
<p>1</p>	<p>FB-F150-P702-21-PR-ASM6L</p>	<p>P702 F-150 Lower Base Plate Mount Welded Assy LH</p>	
<p>1</p>	<p>B-0797R</p>	<p>Toro Indicator Repeater Bracket RH</p>	
<p>1</p>	<p>B-0797L</p>	<p>Toro Indicator Repeater Bracket LH</p>	

1	B-1008R	RAM 2500 DJ2 Halo Fog Light Bracket RH	
1	B-1008L	RAM 2500 DJ2 Halo Fog Light Bracket LH	
1	B-1099	P702 F-150 Pan Brace	
1	B-1100R	P702 F-150 ACC Radar Bracket RH	
1	B-1100L	P702 F-150 ACC Radar Bracket LH	
1	B-1101	P702 F-150 Front Camera Backing Plate	
1	B-1102	P702 F-150 Front Camera Cover	
1	B-1115	P702 F-150 Lower Bash Plate Air Guide	
1	B-1118R	P702 F-150 Fender Guard Cover Plate RH	
1	B-1118L	P702 F-150 Fender Guard Cover Plate LH	

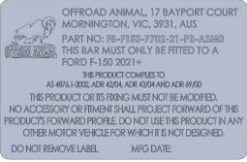
1	B-1119	P702 F-150 Intercooler Air Guide	
1	B-1266R	P702 F-150 Intersection Assist Radar Clamp Bracket Outer	
1	B-1266L	P702 F-150 Intersection Assist Radar Clamp Bracket Outer	
1	B-1267R	P702 F-150 Intersection Assist Radar Clamp Bracket Inner	
1	B-1267L	P702 F-150 Intersection Assist Radar Clamp Bracket Inner	
1	B-1268R	P702 F-150 Pre- Facelift Plastic Bumper Support RH	
1	B-1268L	P702 F-150 Pre- Facelift Plastic Bumper Support LH	
1	B-1300	P702 F-150 Number Plate Flip Bracket	
1	M-00030R	Wing Mesh Panel - Toro With Indicator Repeater RH	
2	M-00030L	Wing Mesh Panel - Toro With Indicator Repeater LH	

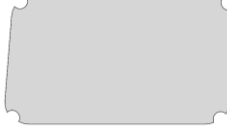
10	P-0344	P702 F-150 Impact Assy Spacer Block	
1	P-0396	P702 F-150 Intercooler Active Shutter Motor Pin Holder	
1	T-0096	P702 F-150 Intercooler Active Shutter Motor Spacer 15mm	
1	T-0097	P702 F-150 Intercooler Active Shutter Motor Spacer 23.5mm	
1	T-0115	P702 F-150 Intercooler Active Shutter Motor Spacer 12.5mm	
1	T-0116	P702 F-150 Intercooler Active Shutter Motor Spacer 8.5mm	
1	U-0072	P702 F-150 Bash Plate	
1	U-0073R	P702 F-150 Side Underpanel RH	
1	U-0073L	P702 F-150 Side Underpanel LH	
1	U-0074	P702 F-150 Lower Bash Plate	
1	11CAT1M-2	LED Autolamps 11CAT1M-2 Front Indicator - Twin Blister Pack	

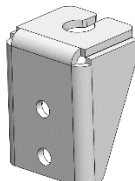
6	CPHP032	Plastic Hole Insert, 20MM, Black, Tigerlink Hardware CPHP032	
6	F-0030	Parking Sensor Holder - Universal, Flat	
1	TK-COM-PSEN-6	Tape Kit - 6 Sensor Universal	N/A
1	FB-F150-P702-21-PR-ADRCP	ADR Compliance Plate Ford F-150 (P702)	
1	FI Note	Fitting Instruction Note	N/A
1	N-0010	P702 F-150 ACC Radar Cover Panel	
1	N-0014R	P702 F-150 Intersection Assist Radar Cover Panel RH	
1	N-0014L	P702 F-150 Intersection Assist Radar Cover Panel LH	
1	OFA-LOGO	Offroad Animal Metal Logo	
TORO ONLY			
2	B-0649	Toro Antenna Bracket – 90 Degree Tall	

PREDATOR Fasteners – Contained in Small Parts Kit Bag

Qty	Part Number	Description
4	M3X12 PAN	SCREW, PAN HEAD PHILLIPS, M3X12X0.5 GR4.6 ZP
4	M3 FLAT WASHER	Flat Washer M3, 7mmODx0.5mm T
4	M3 NUT	Hex Nut, M3x0.5 G48.8 ZP
8	M4X12 PAN	SCREW, PAN HEAD PHILLIPS, M4X12X0.7 GR4.6 ZP
3	M4X50 PAN	SCREW, PAN HEAD PHILLIPS, M4X50X0.7 GR4.6 ZP
10	M4 FLAT WASHER	Flat Washer M4, 8mmODx0.8mm T
11	M4 FLANGE NUT	Flange Nut, M4
4	M5X15 BHCS BZP	SCREW, BUTTON HEAD CAP, M5X15X0.8 GR12.9 ISO4042 ZnNi BLACK PASSIVATED FINISH
2	M5X20 PAN	SCREW, PAN HEAD PHILLIPS, M5X20X0.8 GR4.6 ZP
4	M5 Flat washer BZP	M5 Flat Washer, 10x5.3x1, ISO4042 ZnNi BLACK PASSIVATED FINISH
2	M5 Flat washer	M5 Flat Washer, 10x5.3x1
1	M5 Mud Guard Washer	3/16" x 3/4" x 18g (M5 x 19mm x 1.2mm) Zinc Mudguard Washer
6	M5 FLANGE NUT	Flange Nut, M5x0.8 G8.8 ZP
52	M6x16 BHCS BLACK ZINC	SCREW, BUTTON HEAD CAP, M6X16X1 GR12.9, ISO4042 ZnNi BLACK PASSIVATED FINISH
2	M6 X 20 HEX	M6X20 HEX BOLT, ZP, 8.8
54	M6 FLAT WASHER BLACK ZINC	M6 Flat Washer, 12x6.1x1, ISO4042 ZnNi BLACK PASSIVATED FINISH
39	M6 FLANGE NUT	Flange Nut, M6x1 G8.8 ZP
12	M6CN3MM	CAGE NUT M6x2.6-3.5
6	M8 X 20 BHCS BLACK ZINC	SCREW, BUTTON HEAD CAP, M8X20X1.25, ISO4042 ZnNi BLACK PASSIVATED FINISH
10	M8 X 20 HEX	Bolt Hex, M8X20x1.25, GR8.8 ZP
6	M8 HD FLAT WASHER - BZP	M8 FLAT WASHER - High Tensile 19x8x2mm, ISO4042 ZnNi BLACK PASSIVATED FINISH
6	M8 HD FLAT WASHER	M8 FLAT WASHER - High Tensile 19x8x1.9mm
6	M8 FLAT WASHER	M8 FLAT WASHER
2	M8 NYW	Washer, M8, Nylon
6	M8 FLANGE NUT	Flange Nut, M8x1.25 G8.8 ZP
2	M8 NYLOC	NYLOC SELF LOCKING NUT, ST STL A2 ISO
2	M10X30 BHCS	SCREW, BUTTON HEAD CAP, M10X30X1.5 GR12.9 ZP
8	M10 X 40	Bolt Hex, M10X40X1.5, GR8.8 ZP
10	M10 FW LHD	WASHER, FLAT M10X28.5X2.5
6	M10 FLANGE NUT	Flange Nut, M10x1.5 G8.8 ZP
8	M12X30	Bolt Hex, M12X30x1.75, GR8.8 ZP
4	M12X35	Bolt Hex, M12X35x1.75, GR8.8 ZP
4	M12X60	Bolt Hex, M12X60x1.75, GR8.8 ZP
18	M12 FW LHD	M12 FW Large Heavy Duty
12	M12 FLANGE NUT	Flange Nut, M12x1.75 G8.8 ZP
2	M12 Nyloc nut	M12 NYLOC NUT
2	NP-COM-M12-300- ASM0	M12 NUT PLATE 300MM STEM

TORO Fasteners – Contained in Small Parts Kit Bag

Qty	Part Number	Description
4	M3X12 PAN	SCREW, PAN HEAD PHILLIPS, M3X12X0.5 GR4.6 ZP
4	M3 FLAT WASHER	Flat Washer M3, 7mmODx0.5mm T
4	M3 NUT	Hex Nut, M3x0.5 G48.8 ZP
8	M4X12 PAN	SCREW, PAN HEAD PHILLIPS, M4X12X0.7 GR4.6 ZP
3	M4X50 PAN	SCREW, PAN HEAD PHILLIPS, M4X50X0.7 GR4.6 ZP
10	M4 FLAT WASHER	Flat Washer M4, 8mmODx0.8mm T
11	M4 FLANGE NUT	Flange Nut, M4
4	M5X15 BHCS BZP	SCREW, BUTTON HEAD CAP, M5X15X0.8 GR12.9 ISO4042 ZnNi BLACK PASSIVATED FINISH
2	M5X20 PAN	SCREW, PAN HEAD PHILLIPS, M5X20X0.8 GR4.6 ZP
4	M5 Flat washer BZP	M5 Flat Washer, 10x5.3x1, ISO4042 ZnNi BLACK PASSIVATED FINISH
2	M5 Flat washer	M5 Flat Washer, 10x5.3x1
1	M5 Mud Guard Washer	3/16" x 3/4" x 18g (M5 x 19mm x 1.2mm) Zinc Mudguard Washer
6	M5 FLANGE NUT	Flange Nut, M5x0.8 G8.8 ZP
52	M6x16 BHCS BLACK ZINC	SCREW, BUTTON HEAD CAP, M6X16X1 GR12.9, ISO4042 ZnNi BLACK PASSIVATED FINISH
2	M6 X 20 HEX	M6X20 HEX BOLT, ZP, 8.8
54	M6 FLAT WASHER BLACK ZINC	M6 Flat Washer, 12x6.1x1, ISO4042 ZnNi BLACK PASSIVATED FINISH
39	M6 FLANGE NUT	Flange Nut, M6x1 G8.8 ZP
12	M6CN3MM	CAGE NUT M6x2.6-3.5
10	M8 X 20 BHCS BLACK ZINC	SCREW, BUTTON HEAD CAP, M8X20X1.25, ISO4042 ZnNi BLACK PASSIVATED FINISH
10	M8 X 20 HEX	Bolt Hex, M8X20x1.25, GR8.8 ZP
10	M8 HD FLAT WASHER - BZP	M8 FLAT WASHER - High Tensile 19x8x2mm, ISO4042 ZnNi BLACK PASSIVATED FINISH
6	M8 HD FLAT WASHER	M8 FLAT WASHER - High Tensile 19x8x1.9mm
6	M8 FLAT WASHER	M8 FLAT WASHER
2	M8 NYW	Washer, M8, Nylon
6	M8 FLANGE NUT	Flange Nut, M8x1.25 G8.8 ZP
2	M8 NYLOC	NYLOC SELF LOCKING NUT, ST STL A2 ISO
2	M10X30 BHCS	SCREW, BUTTON HEAD CAP, M10X30X1.5 GR12.9 ZP
8	M10 X 40	Bolt Hex, M10X40X1.5, GR8.8 ZP
10	M10 FW LHD	WASHER, FLAT M10X28.5X2.5
6	M10 FLANGE NUT	Flange Nut, M10x1.5 G8.8 ZP
8	M12X30	Bolt Hex, M12X30x1.75, GR8.8 ZP
4	M12X35	Bolt Hex, M12X35x1.75, GR8.8 ZP
4	M12X60	Bolt Hex, M12X60x1.75, GR8.8 ZP
18	M12 FW LHD	M12 FW Large Heavy Duty
12	M12 FLANGE NUT	Flange Nut, M12x1.75 G8.8 ZP
2	M12 Nyloc nut	M12 NYLOC NUT
2	NP-COM-M12-300- ASM0	M12 NUT PLATE 300MM STEM

TOOLS REQUIRED

The following tools will be required to install the product.

Hand Tools	Power Tools	Workshop Equipment
Metric Socket Set 5.5-21mm	Angle grinder	Tape Measure
Socket Extension Bar	Electric/Air Impact Driver (Optional)	Isopropyl Alcohol
Metric Spanner Set 5.5-21mm	Electric drill	Rag
Hex (Allen) Key Set 3-6mm	Soldering Iron	Cable Ties
Torx Key Set	Air hacksaw or Jigsaw	Solder
Trim Removal Tool	Heat Gun	Heatshrink
Plastic Auto Trim Tool Set		Electrical Tape
Flat Blade Screwdriver Set		Marker Pen
Phillips Head Screwdriver Set		Masking Tape
Utility Knife		Crimp Terminals (Optional)
Side Cutters		Electrical Conduit (Optional)
Pliers		Automotive Electrical Wire (Optional)
Wire Strippers		Lifting Trolley (Optional)
Crimping Tool (Optional)		Sandpaper
4mm Drill Bit		Automotive adhesive sealant (eg. Sikaflex)

WORKSHOP SAFETY

It is the responsibility of the installer to always complete works in a safe manner. Make sure the following safety equipment is available and precautions are observed whilst fitting this product.

<p>Hearing Protection</p> 	<p>Always wear ear protection when using power tools.</p>
<p>Eye Protection</p> 	<p>Ensure eye protection is always worn when cutting or drilling.</p>
<p>Manual Handling</p> 	<p>Do not attempt to lift bar assemblies or rock sliders on your own.</p> <p>Always use two people to lift or use mechanical Lifting aid such as hydraulic lifting trolley.</p>
<p>Vehicle Support</p> 	<p>Always ensure vehicle is properly supported when working on it. Do not attempt to fit products whilst suspension work is being carried out. Do not work under a vehicle supported only by a jack.</p>



<p>DO NOT turn on or move car whilst any camera or radar systems are disconnected.</p> <p>Failure to observe this precaution will result in system errors that will need car to be taken to a Ford Dealership to resolve.</p> <p>Keep proximity keys away from vehicle and out of range to minimise the chances of onboard vehicle computers activating whilst modules are disconnected.</p>	<p>TOOLS REQUIRED</p>
<p><u>2026 MARCH UPDATE</u> This product will suit facelift XLT, Lariat and Platinum models. Bumper/grille removal procedure will differ slightly.</p> <p>1. Remove the number plate and set aside.</p>	<p>FASTENERS</p>

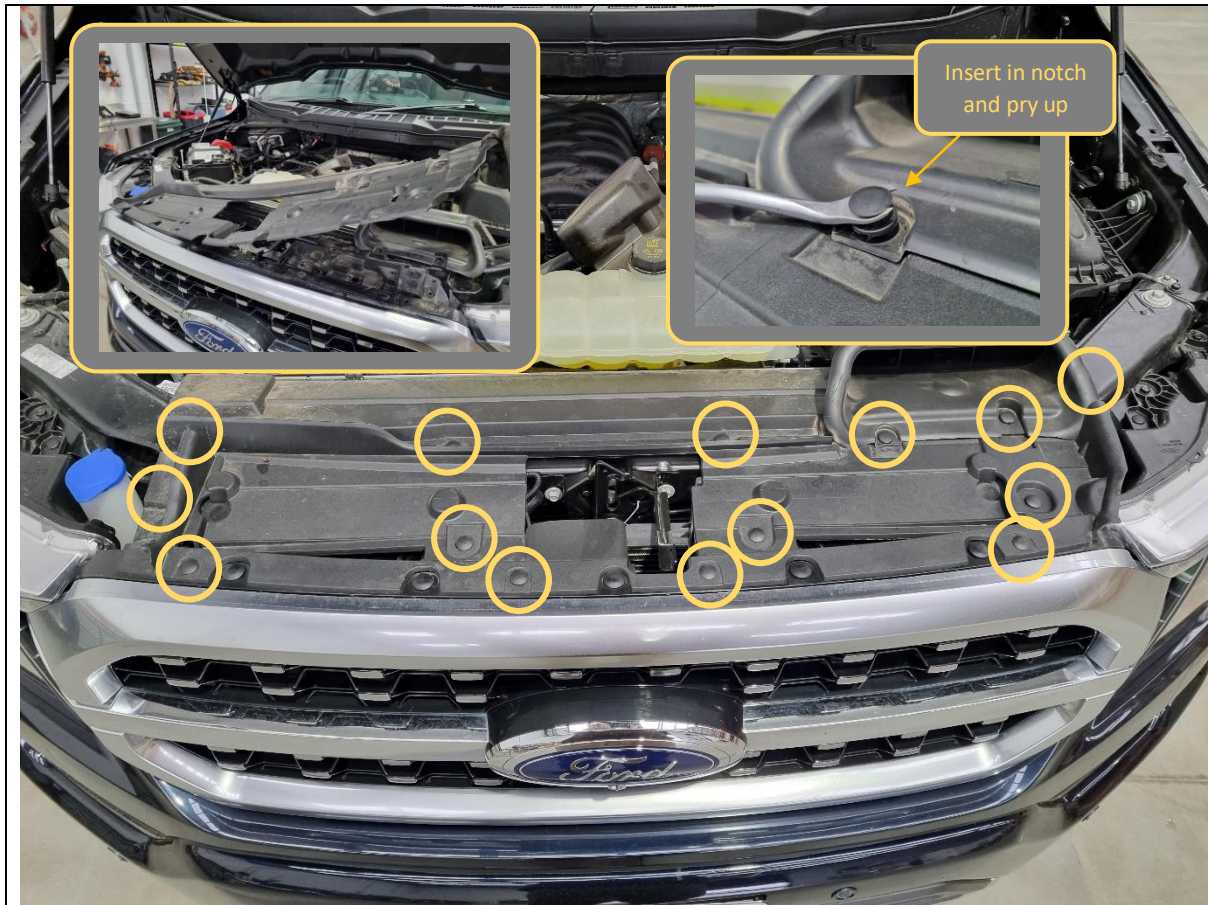

2. Open the bonnet.

3. Remove 14x plastic push rivets securing the radiator grille cover, by levering centre section upwards using flat bladed screwdriver or trim tool, as shown. Note the radiator grille cover also sits underneath the air intake.

TOOLS REQUIRED

Trim tool
or
Flat blade screwdriver

FASTENERS

14x Plastic Push Rivet

Retain for Reassembly



4. Remove 2x 7mm hex bolts securing the plastic bumper trim to the inner wheel guard, on each side.

TOOLS REQUIRED

7mm socket/spanner

FASTENERS

4x 7mm factory hex bolts



5. Pull and release the clips holding the plastic bumper trim. Set aside for later.

TOOLS REQUIRED

FASTENERS

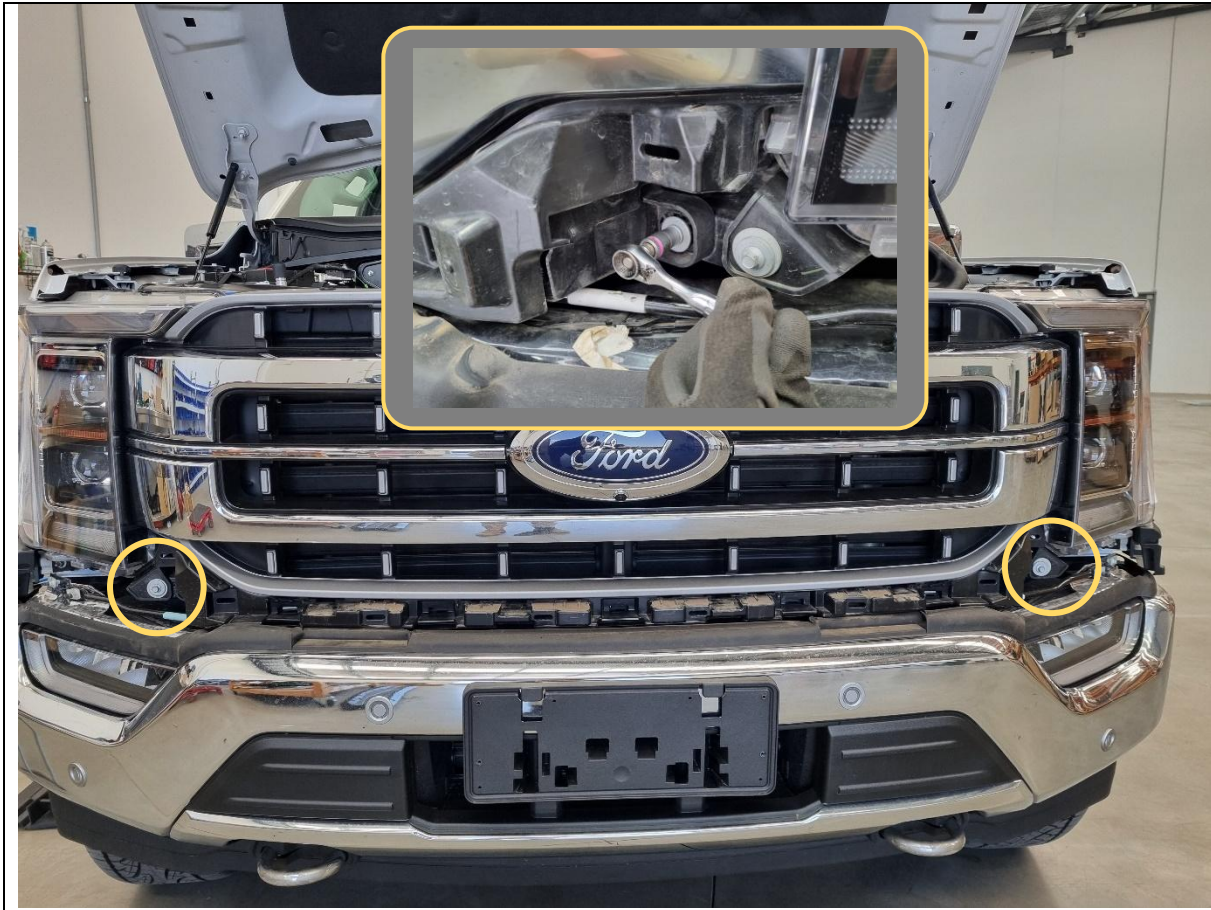

6. Remove 1x 8mm hex bolt securing the outer corner of the grille to the body, on each side.

TOOLS REQUIRED

8mm socket/spanner

FASTENERS

2x 8mm factory hex bolts

Retain for Reassembly

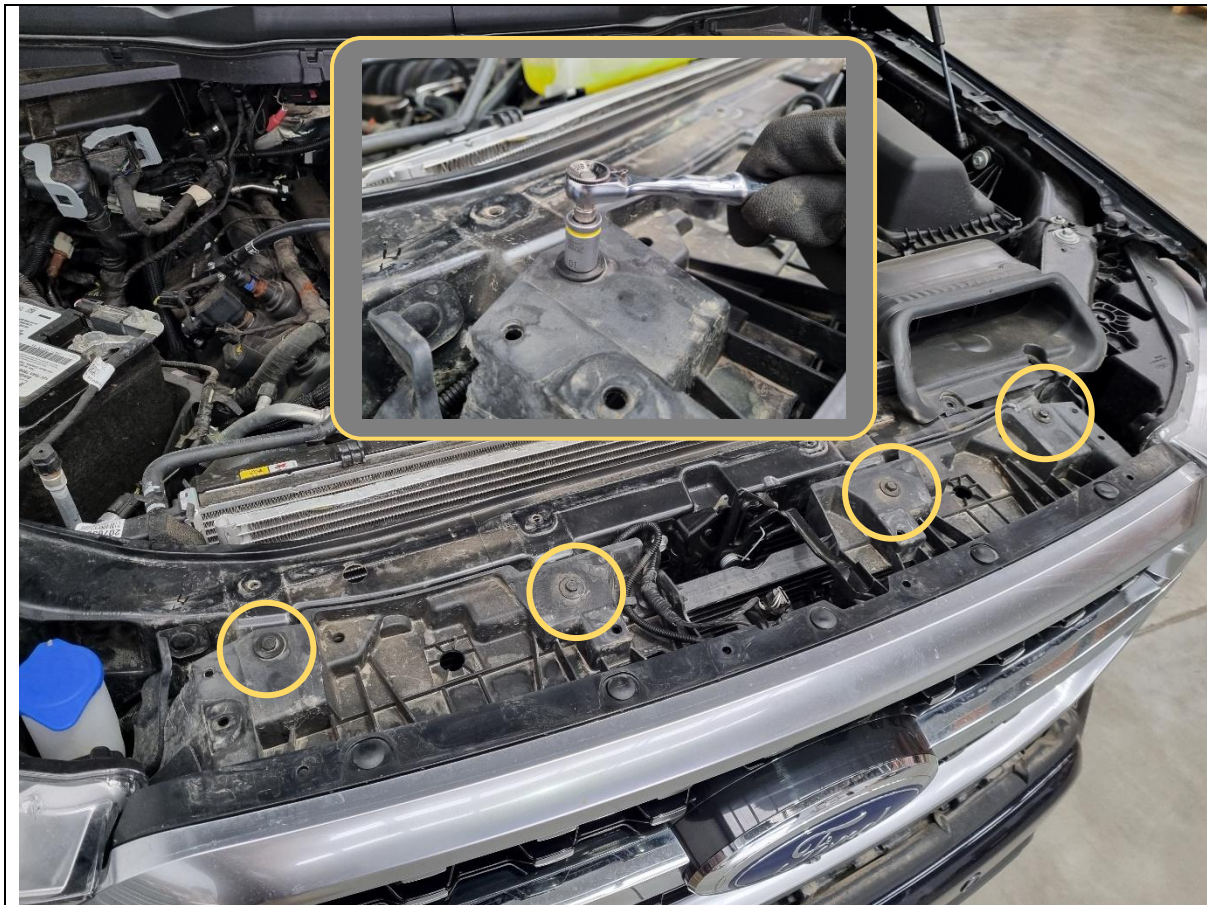

7. Remove 4x 10mm hex bolts securing the top of the grille to the body.

TOOLS REQUIRED

10mm socket/spanner

FASTENERS

4x 10mm factory hex bolts

Retain for Reassembly

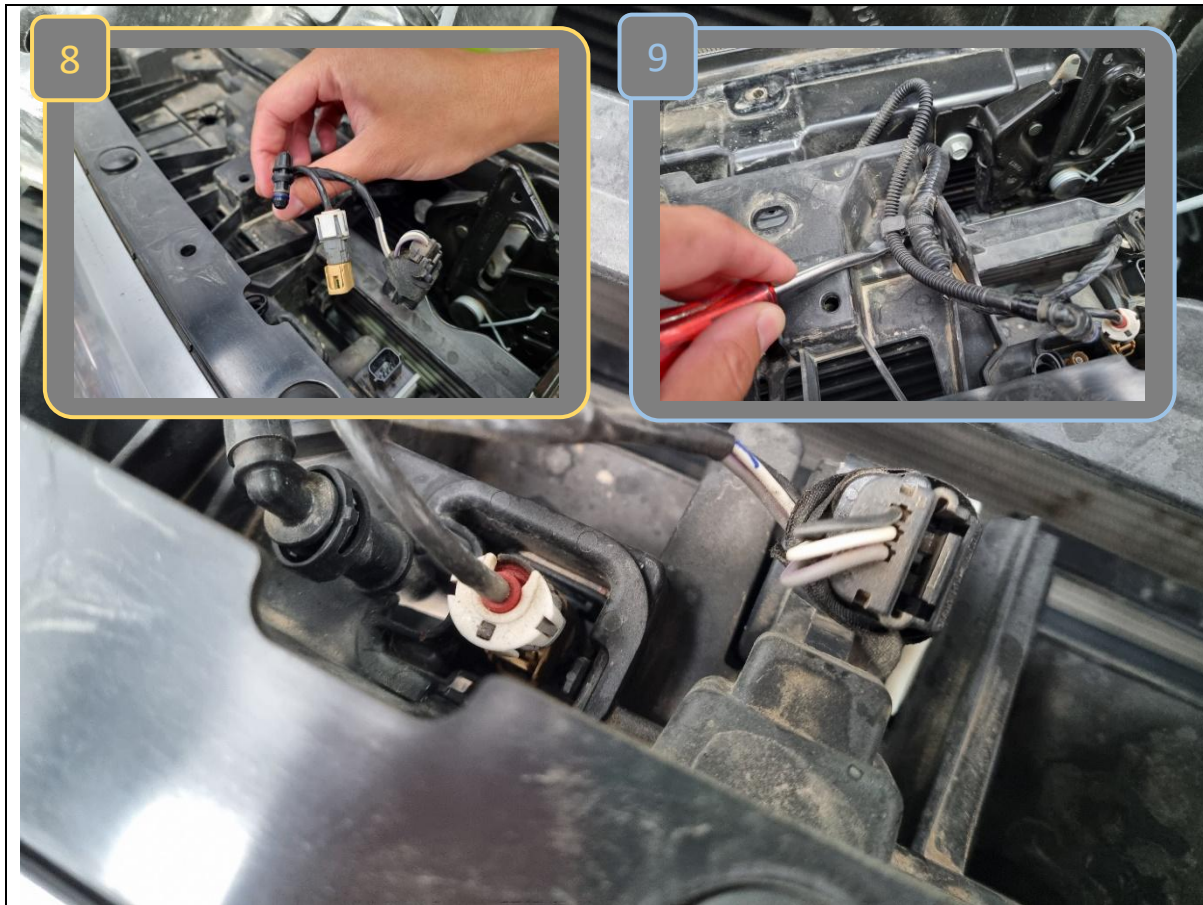

8. Locate the harness connectors on the top centre of the grille. Disconnect the main harness, camera harness (if equipped) and camera washer hose (if equipped).
9. Unclip the harness from the grille with a flat bladed screwdriver or trim tool.

TOOLS REQUIRED

Trim tool
or
Flat blade screwdriver

FASTENERS



10. Pull outwards and remove the grille. Set aside for later.

TOOLS REQUIRED

FASTENERS



11. Locate the main bumper harness on top of the RH chassis frame end.
12. Pull up on the lever and disconnect the harness.
13. Unclip the harness loose from the chassis frame.

TOOLS REQUIRED

Trim tool
or
Flat blade screwdriver

FASTENERS

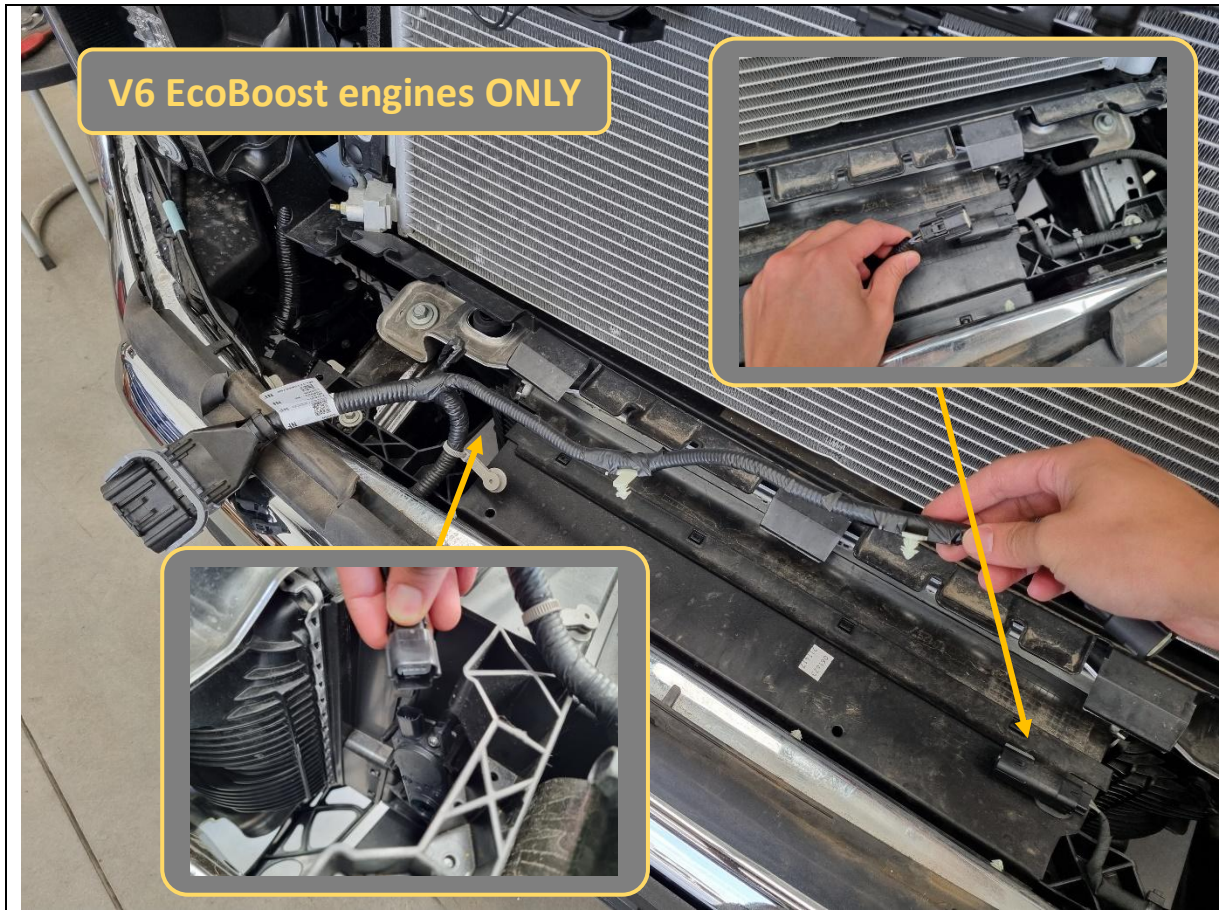

14. On vehicles with 3.5L V6 EcoBoost engines, disconnect the 2x harnesses around the intercooler shroud.

15. Unclip the harness from the intercooler shroud.

TOOLS REQUIRED

Trim tool
or
Flat blade screwdriver

FASTENERS

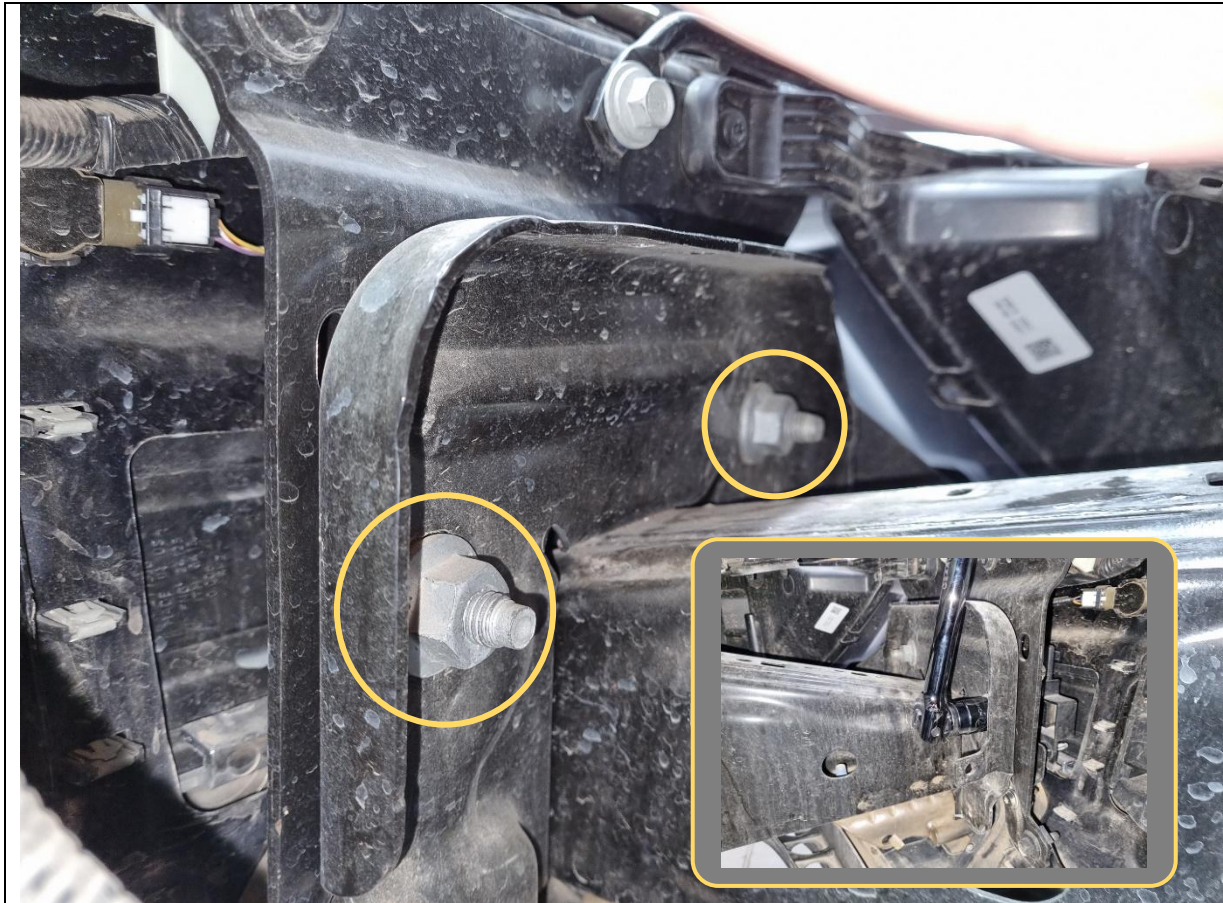

16. Remove the 3x 21mm hex nuts holding the bumper onto the chassis frame end, on each side.

TOOLS REQUIRED

21mm socket/spanner

FASTENERS

6x 21mm factory hex nuts



17. Pull the bumper off the vehicle and set aside in a safe place.

TOOLS REQUIRED

FASTENERS

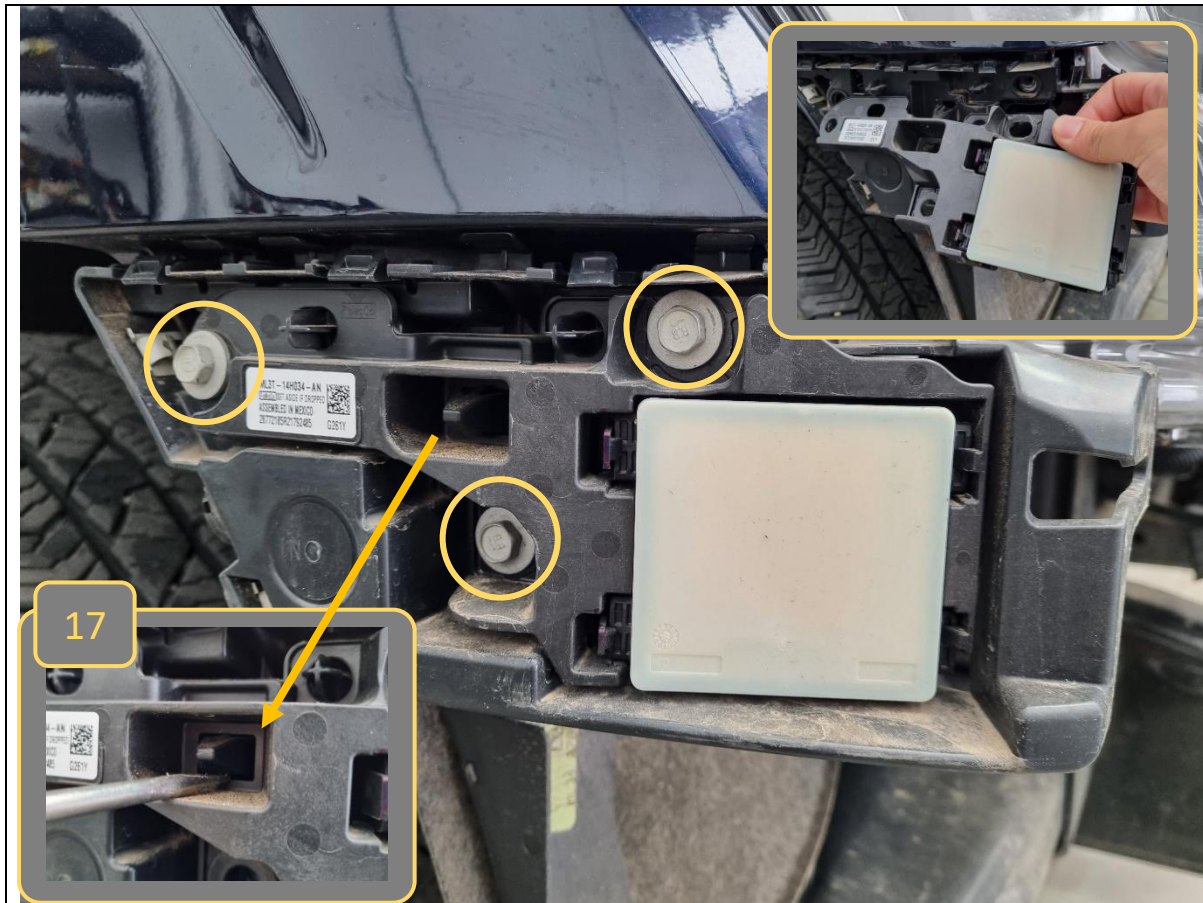

18. Remove 3x 10mm hex bolts securing the bumper clip, on each side.
19. If intersection collision assist (ICA) radars are equipped, press down on the tab with a screwdriver, then pull and release the radar and its plastic holder.
20. Unplug the radar, and carefully set it aside in a safe place. Take note of the radar orientation and LH/RH units.

TOOLS REQUIRED

- 10mm socket/spanner
- Flat blade screwdriver

FASTENERS

- 6x 10mm factory hex bolts

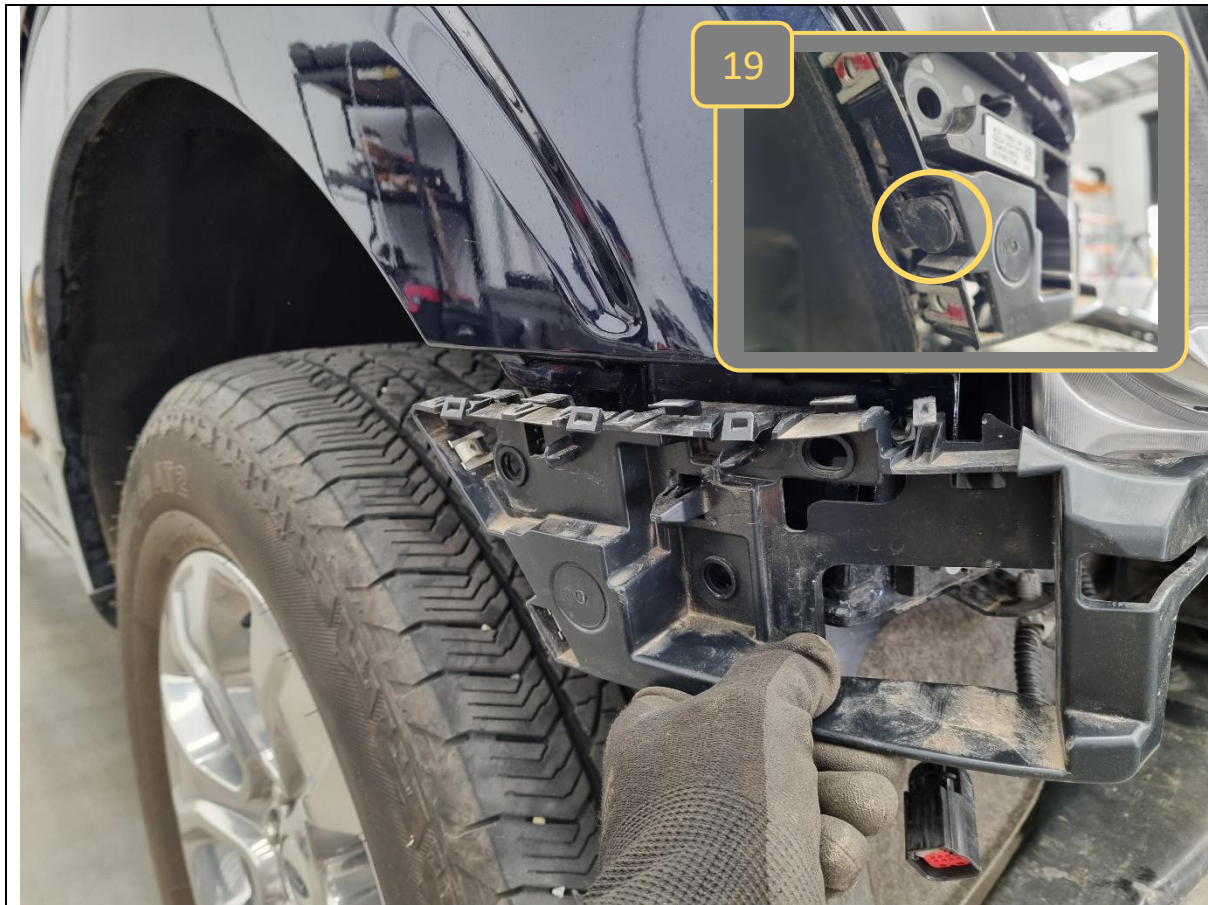

21. Remove the plastic push rivet on the rearwards facing side of the bumper clip, on each side.
22. Pull and remove the bumper clip.

TOOLS REQUIRED

Trim tool
or
Flat blade screwdriver

FASTENERS

2x Plastic Push Rivet



- 23. Remove 2x 7mm hex bolts securing the inner wheel guard to the plastic lower wheel guard trim.
- 24. Remove 1x 10mm hex nut securing the front of the lower wheel guard trim to the headlight/body.
- 25. Unclip the intersection collision assist radar harness, if equipped.
- 26. Remove the lower wheel guard trim. Repeat for other side.

TOOLS REQUIRED

- 7mm socket/spanner
- 10mm socket/spanner

FASTENERS

- 4x factory 7mm hex bolts
- 2x factory 10mm hex nuts



27. Unclip the remainder of the harness on top of the intercooler shroud.

TOOLS REQUIRED

Trim tool
or
Flat blade screwdriver

FASTENERS

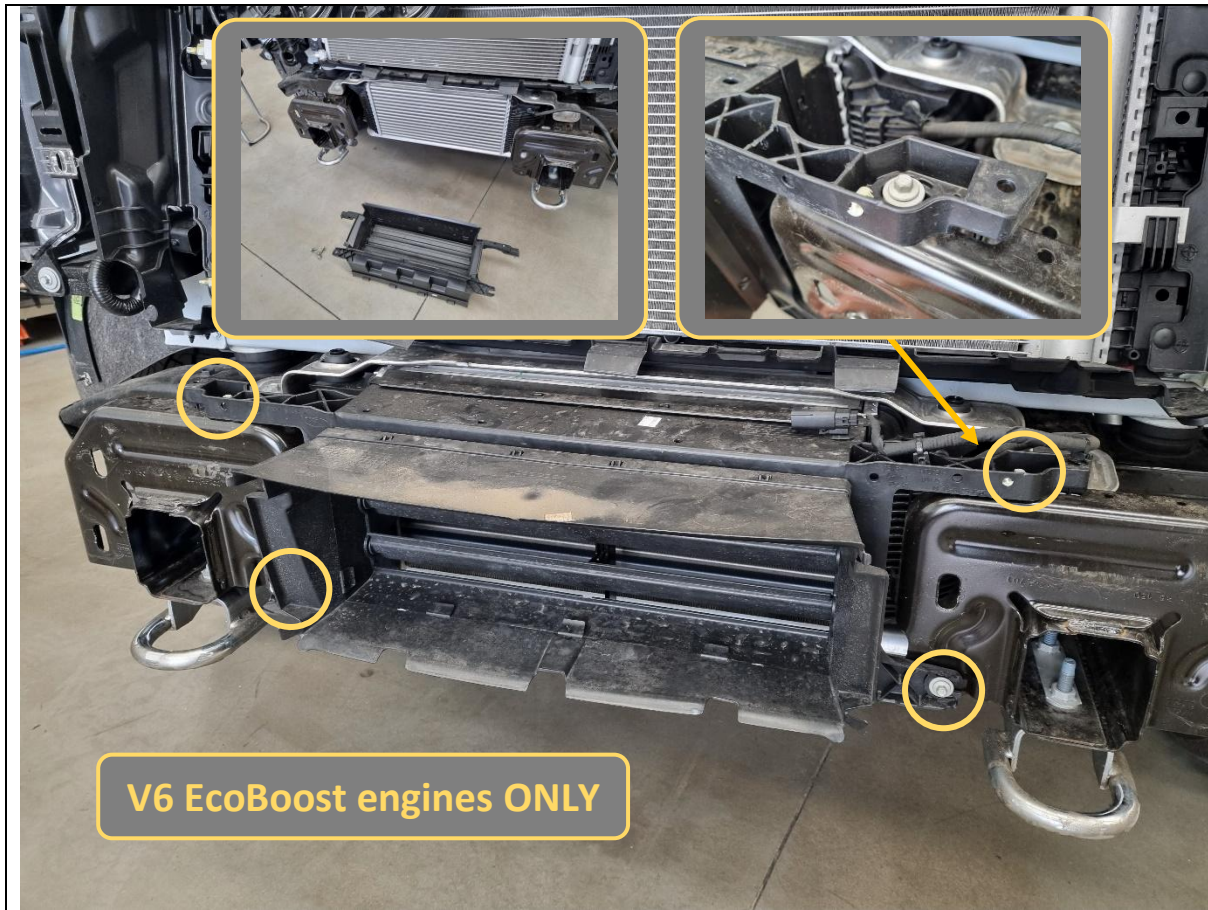

- 28. Remove 4x 8mm hex bolts holding the intercooler shroud.
- 29. Remove the intercooler shroud and set aside in a safe place.

TOOLS REQUIRED

8mm socket/spanner

FASTENERS

4x factory 8mm hex bolts

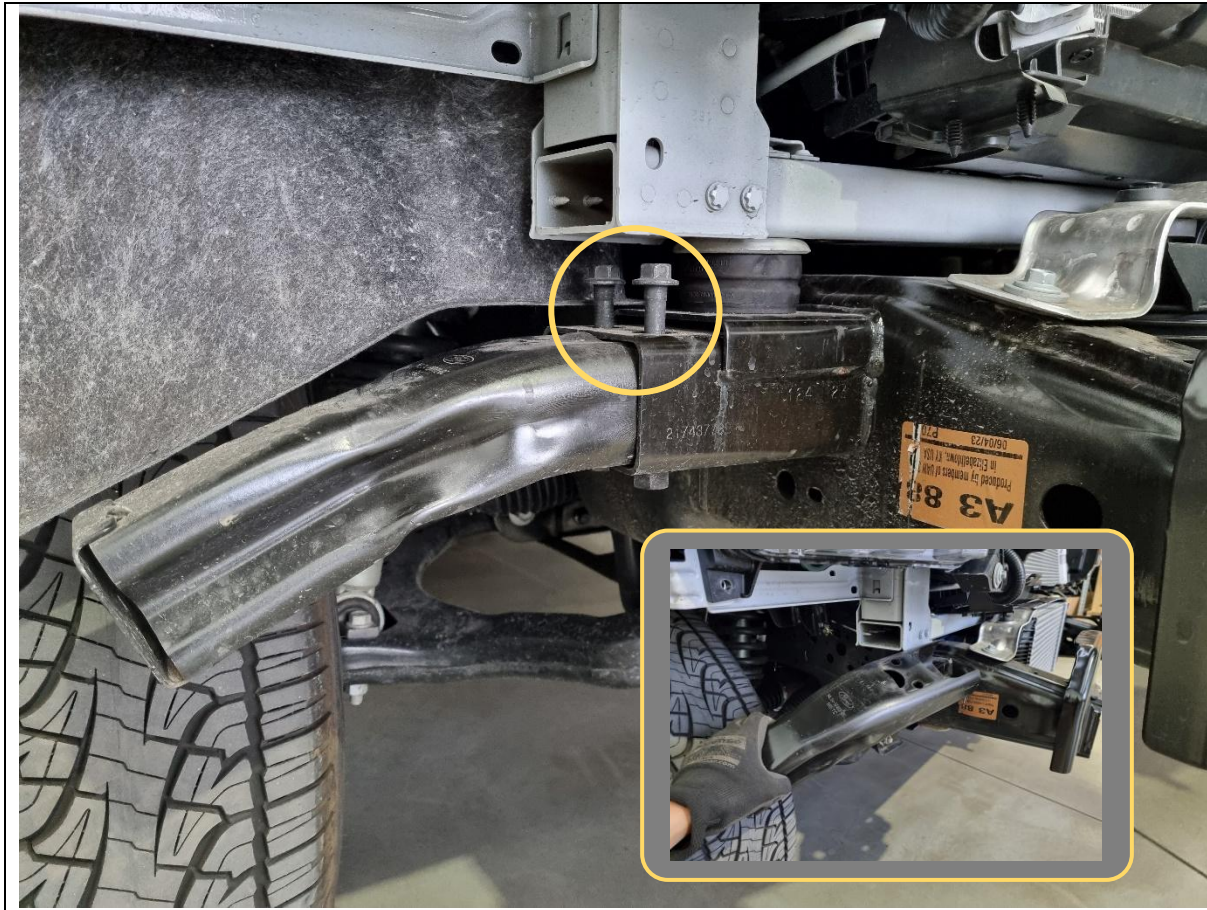

30. Remove the 2x 15mm hex bolts securing the chassis horns on each side of the chassis.

If required, use an angle grinder to cut the bolts free (easier to do after removing wheel arch liners, secured by 7mm hex bolts and plastic push rivets).

31. Remove and discard the chassis horns.

TOOLS REQUIRED

15mm socket/spanner

Angle grinder

FASTENERS

4x 15mm factory hex bolts



32. Remove the 2x 15mm hex bolts and nutplates securing the tow hook to the chassis, on each side. Set aside for re-fitment.

TOOLS REQUIRED

15mm socket/spanner

FASTENERS

4x 15mm factory hex bolts

Retain for Reassembly



<p>33. Manually manipulate the intercooler shutter guide vanes to the fully open and fully closed positions and mark the corresponding rotation on the actuator with a marker pen.</p> <p>34. Avoid opening/closing the shutter guide vanes too many times while doing this as may put too much load on the motor shaft.</p>	<p>TOOLS REQUIRED</p> <p>Marker pen</p>
	<p>FASTENERS</p>



35. Remove the shutter motor by removing the 2x T20 Torx screws securing it to the shroud. Set it aside.

TOOLS REQUIRED

T20 Torx bit

FASTENERS

2x T20 Torx screws



36. Pull up on the tabs and remove the centre guide vane holder (see inset photos).
37. Remove the lower guide vane that was connected to the shutter motor. Discard the rest of the intercooler shroud.

TOOLS REQUIRED

FASTENERS



V6 EcoBoost engines ONLY

<p>38. Cut off the end of the guide vane with the splined motor pin shaft as shown. Keep the motor pin (bottom right inset photo) and discard the rest.</p> <p>39. Clean up the cut face so that it is flat.</p>	<p>TOOLS REQUIRED</p> <p>Air hacksaw or Angle grinder or Jigsaw or Utility knife</p>
	<p>FASTENERS</p>



<p>40. Drill a 4mm hole all the way through the centre of the motor pin (locate with pre-existing hole).</p> <p>41. Insert the motor pin back into the shutter motor from the opposite direction compared to factory.</p> <p>42. Ensure the keying feature (highlighted) is positioned within the open/closed range marked on the motor previously.</p>	<p>TOOLS REQUIRED</p> <p>Electric drill 4mm drill bit</p>
	<p>FASTENERS</p>

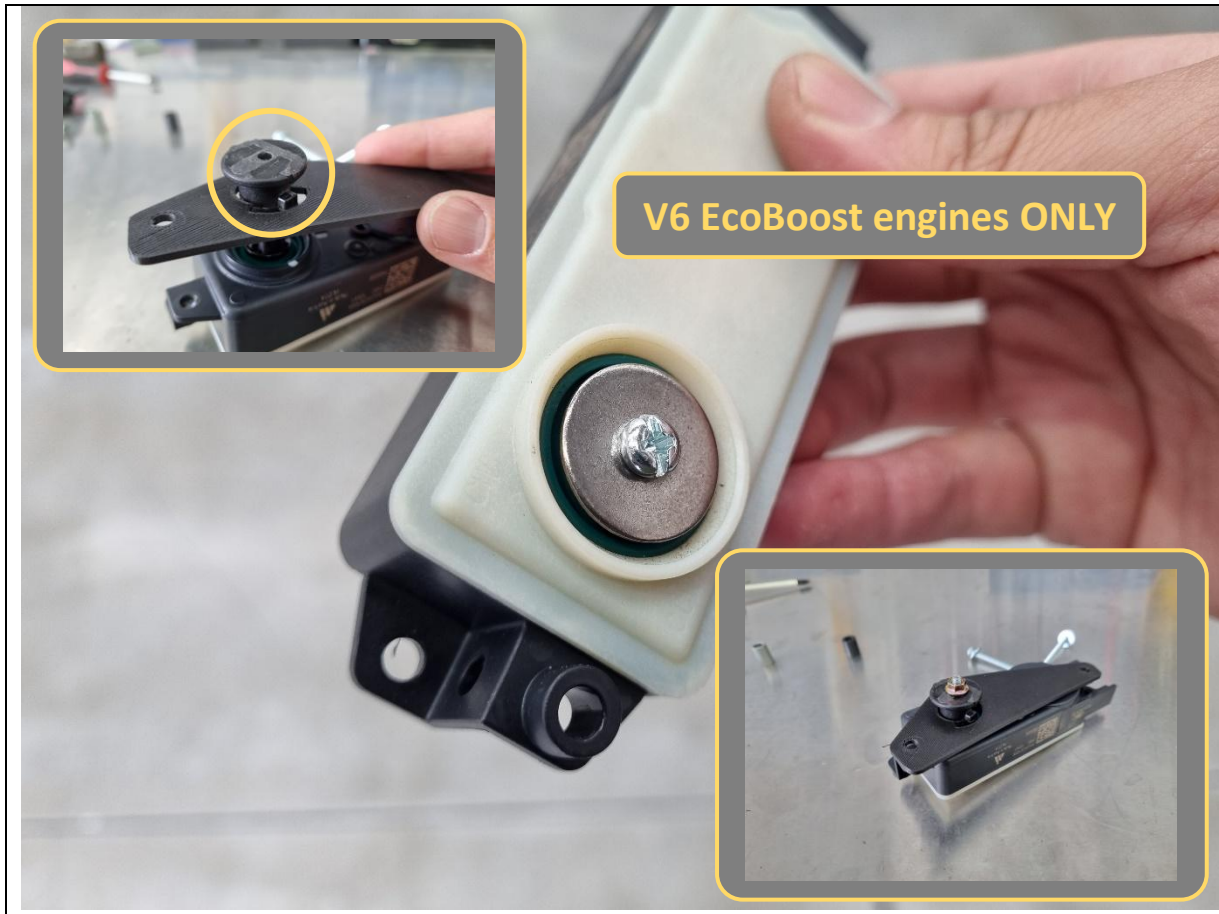

- 43. Fit the P-0396 motor pin holder plate over the motor pin, ensuring the keying feature sits in the cut-out on the holder plate.
- 44. Secure the motor pin to the shutter motor with 1x M4x50 pan head screw, M5 mudguard washer and M4 flange nut as shown. Do not apply too much tightening torque as it may crack the plastic.

TOOLS REQUIRED

Phillips head screwdriver

FASTENERS

1x M4x50 pan head screw
1x M5 mudguard washer
1x M4 flange nut

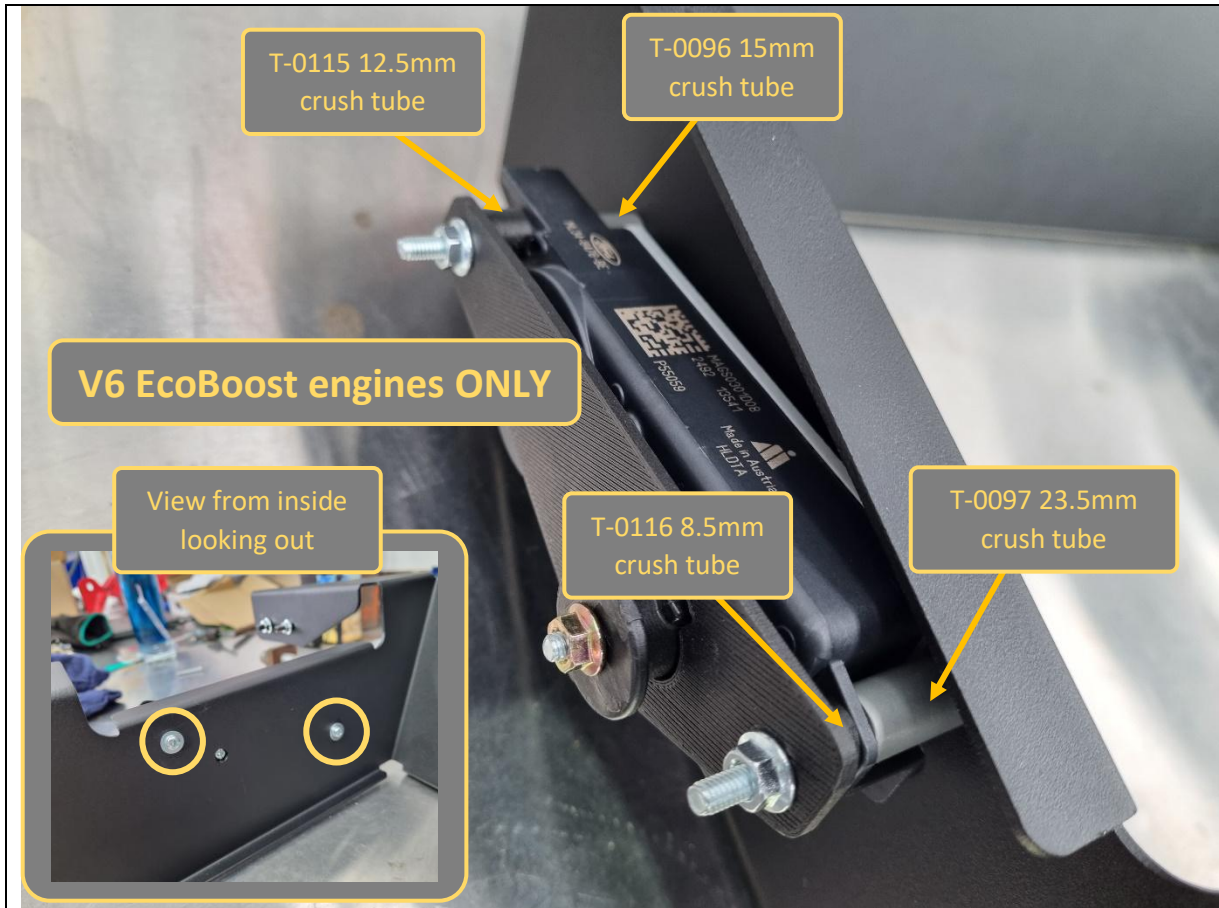

V6 EcoBoost engines ONLY



<p>45. Bolt the shutter motor onto the outside of the supplied sheet metal intercooler shroud use 2x M4x50 pan head screws, washers, crush tubes and flange nuts.</p> <p>46. Refer to photo above for installation order of crush tubes. The shutter motor is sandwiched in between the 4x different length crush tubes.</p>	<p>TOOLS REQUIRED</p> <p>Phillips head screwdriver</p>
	<p>FASTENERS</p> <p>2x M4x50 pan head screw 2x M4 flat washer 2x M4 flange nut</p> <p>1x T-0096 15mm crush tube 1x T-0097 23.5mm crush tube 1x T-0115 12.5mm crush tube 1x T-0116 8.5mm crush tube</p>

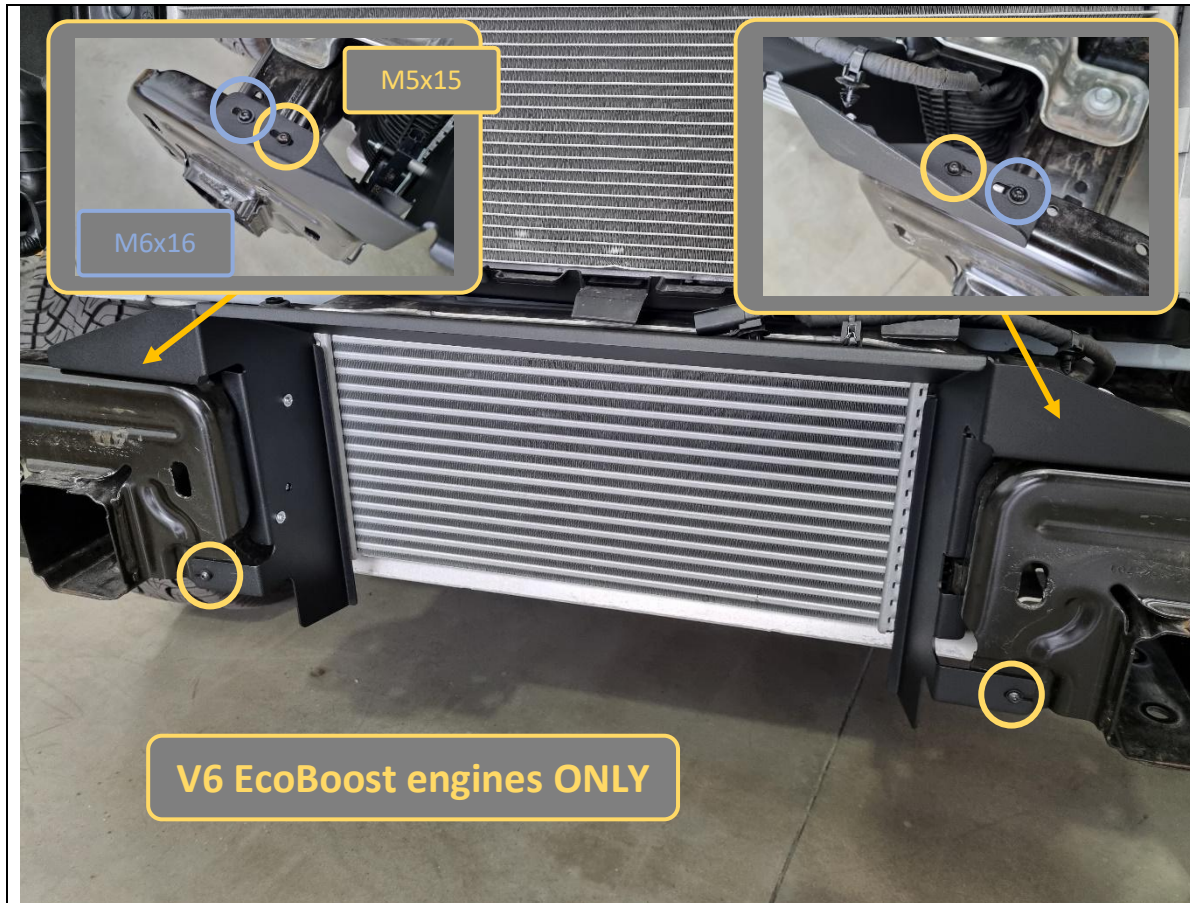

47. Fit the sheet metal shroud onto the vehicle. The shutter motor should be in the same location and orientation as it was originally.
48. Secure it to the same hole locations as the factory plastic intercooler shroud using supplied 4x M5x15 black button head bolts, 2x M6x16 black button head bolts, black washers and flange nuts.

TOOLS REQUIRED

3mm hex/Allen key
4mm hex/Allen key

FASTENERS

4x M5x15 black button head
4x M5 black flat washer
4x M5 flange nut

2x M6x16 black button head
2x M6 black flat washer
2x M6 flange nut



49. Fit the chassis brace to the outside of the frame end, and loosely secure with 1x M12x35 hex bolt, heavy duty flat washer and M12 lollipop nutplate (inserted through the front opening of the chassis, see inset).

50. Repeat for other side.

TOOLS REQUIRED

FASTENERS

- 2x M12x35 hex bolt
- 2x M12 heavy duty washer
- 2x M12 lollipop nutplate

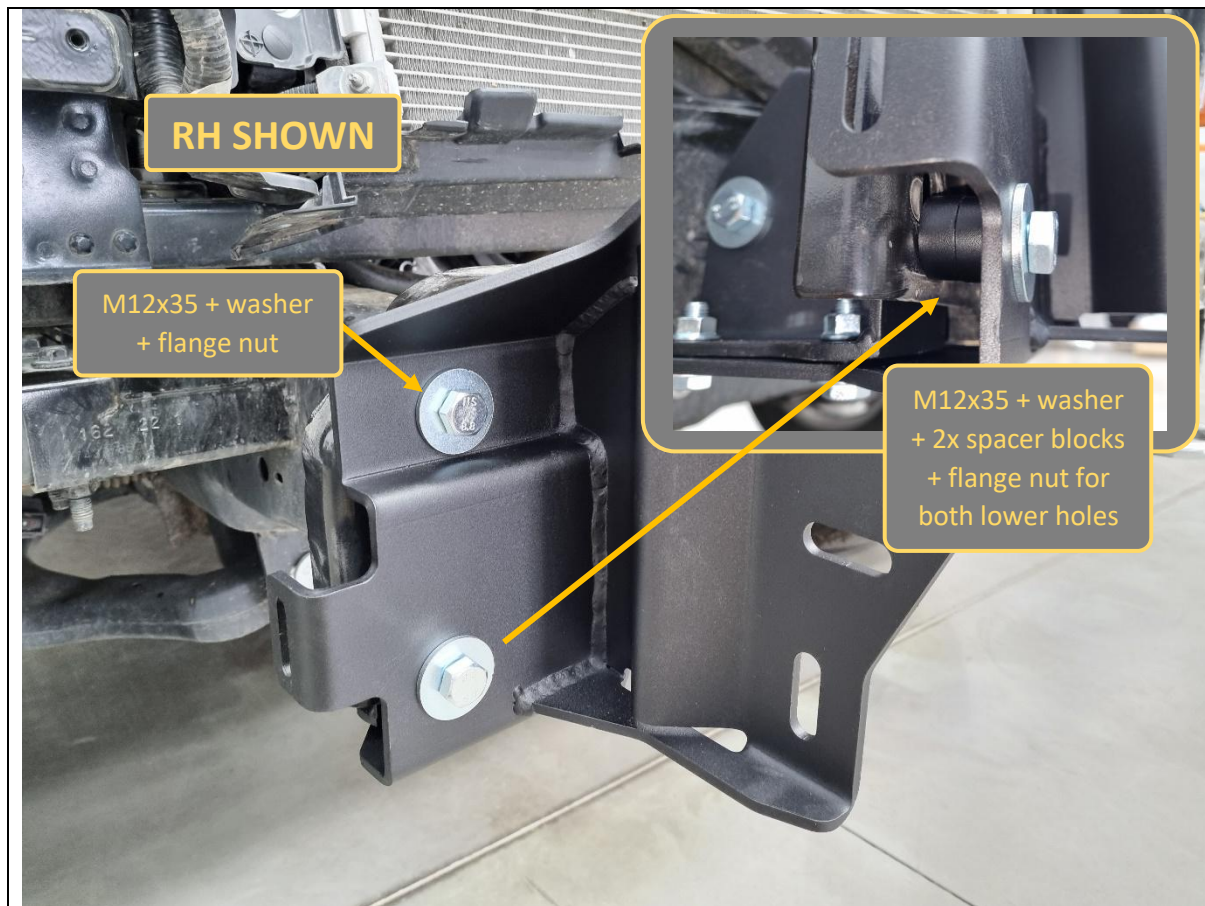

<p>51. Fit the impact assembly onto the chassis and chassis brace.</p> <p>52. Loosely secure top hole to the chassis brace using 1x M12x35 hex bolt, heavy duty washer and flange nut.</p> <p>53. Loosely secure each of the 2x lower holes to the chassis brace using 1x M12x35 hex bolt, heavy duty washer, 2x P-0344 spacer blocks and flange nut.</p>	<p>TOOLS REQUIRED</p>
<p>54. Repeat for other side impact assembly.</p> <p>55. Snug (tighten by hand) all M12 bolts (including the one chassis brace in Step 49) so that there are no gaps to the chassis, but still allow enough freedom to adjust and slide the mounts left/right.</p>	<p>FASTENERS</p> <p>6x M12x35 hex bolt 6x M12 heavy duty washer 8x P-0344 spacer block 6x M12 flange nut</p>



56. Loosely secure the rear of the impact assembly to the chassis brace using 2x M10x40 hex bolts, heavy duty washers and flange nuts.

57. Repeat for other side.

TOOLS REQUIRED

FASTENERS

- 4x M10x40 hex bolt
- 4x M10 heavy duty washer
- 4x M10 flange nut

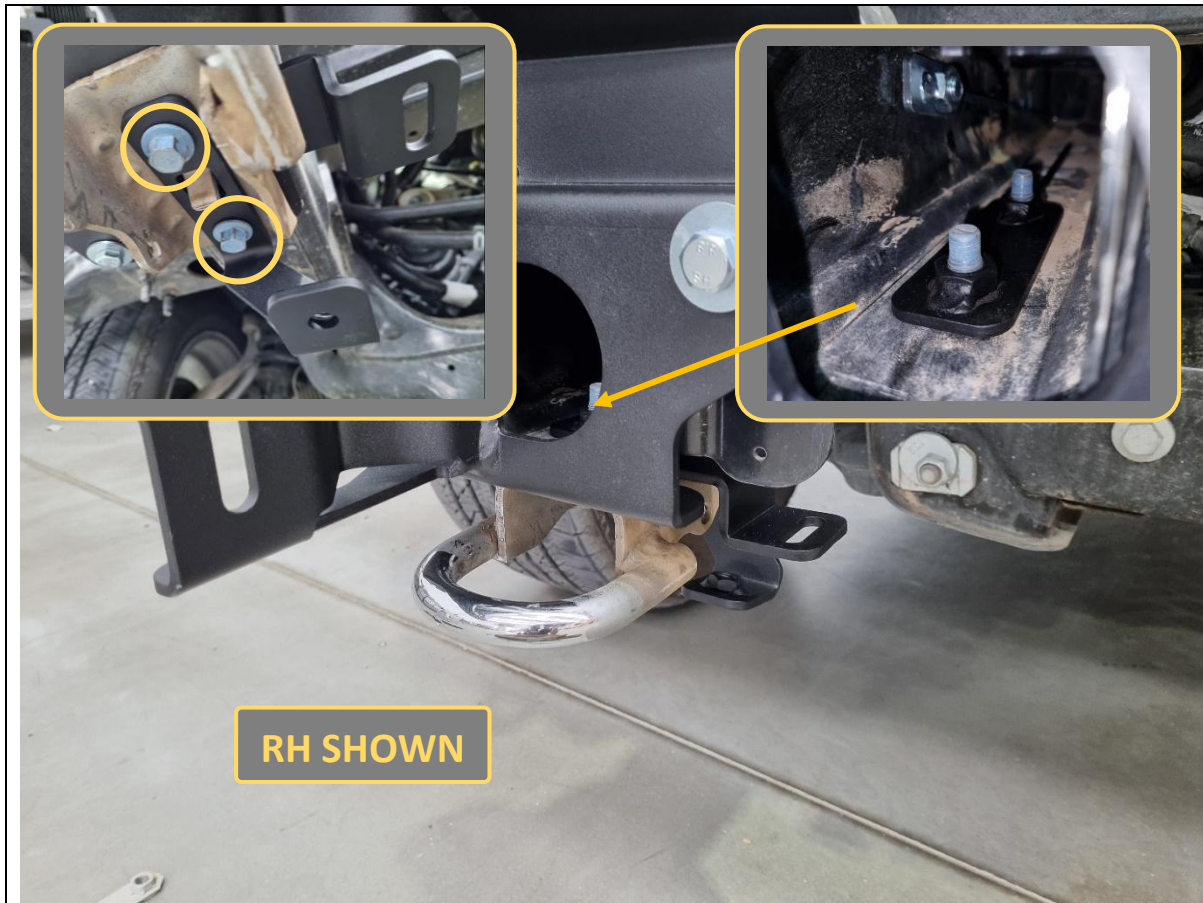

- 58. Re-fit the tow point to the vehicle, along with B-1114 lower bash plate mount bracket.
- 59. Loosely secure with retained 2x 15mm factory hex bolts, and 1x FB-F150-P702-21-PR-ASM5 tow hook nut plate (inserted through the front opening of the chassis, see RH inset).
- 60. Repeat for other side.

TOOLS REQUIRED

FASTENERS

- 4x 15mm factory hex bolts
- 2x FB-F150-P702-21-PR-ASM5 tow hook nut plate

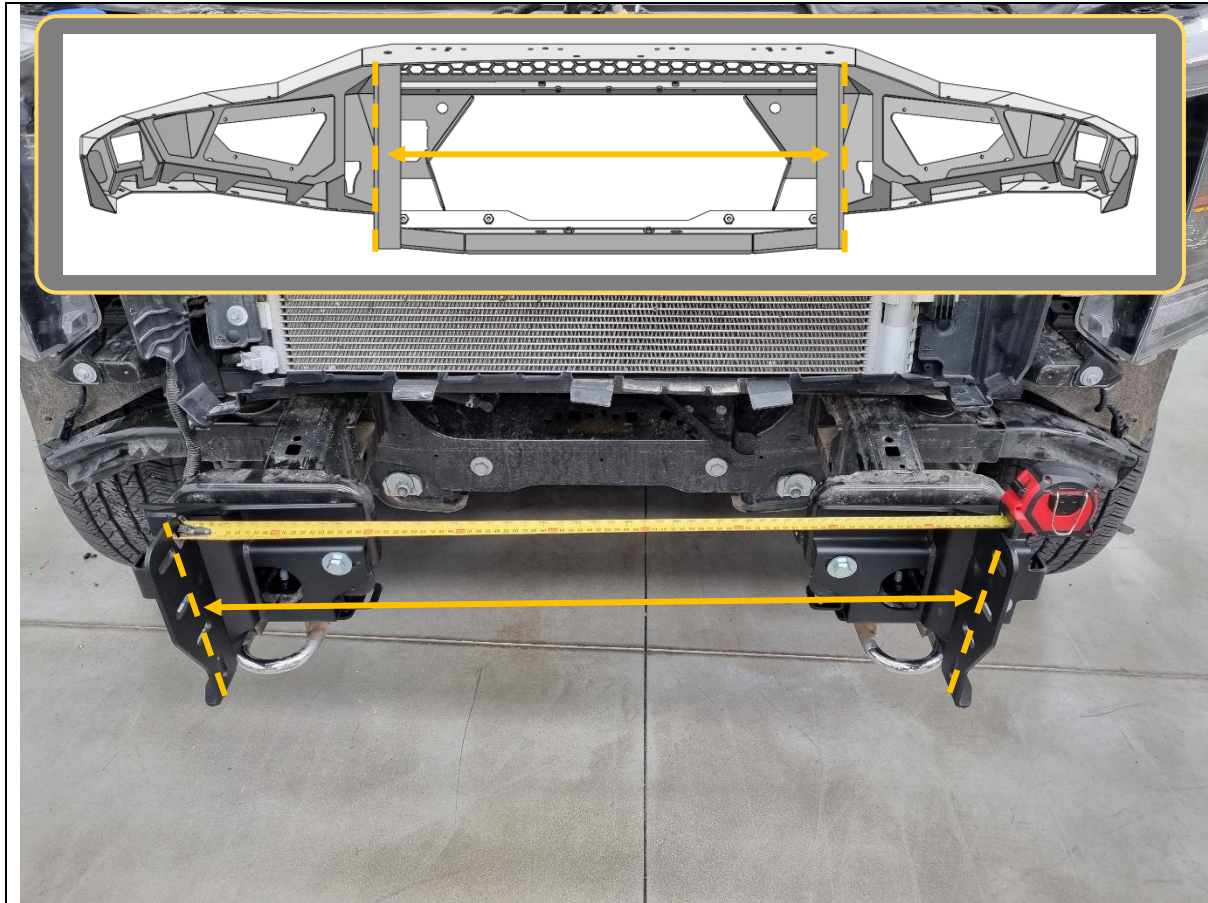

61. Measure the distance between the outside faces of uprights on bar using tape measure. Write distance below for reference if required.

Bar Upright Width = _____mm

62. Adjust mounts by sliding left/right on the slots, such that distance between inner faces of mounts are approximately 2mm more than bar. Ensure the mount faces are vertically upright and symmetric left/right on the chassis.

63. Secure and tighten mounts. Tighten in the following order:

- a. 15mm factory tow hook bolts
- b. M12 hex bolts (including brace)
- c. M10 hex bolts

TOOLS REQUIRED

Tape measure

- 15mm socket/spanner
- 16mm socket/spanner
- 19mm socket/spanner

FASTENERS

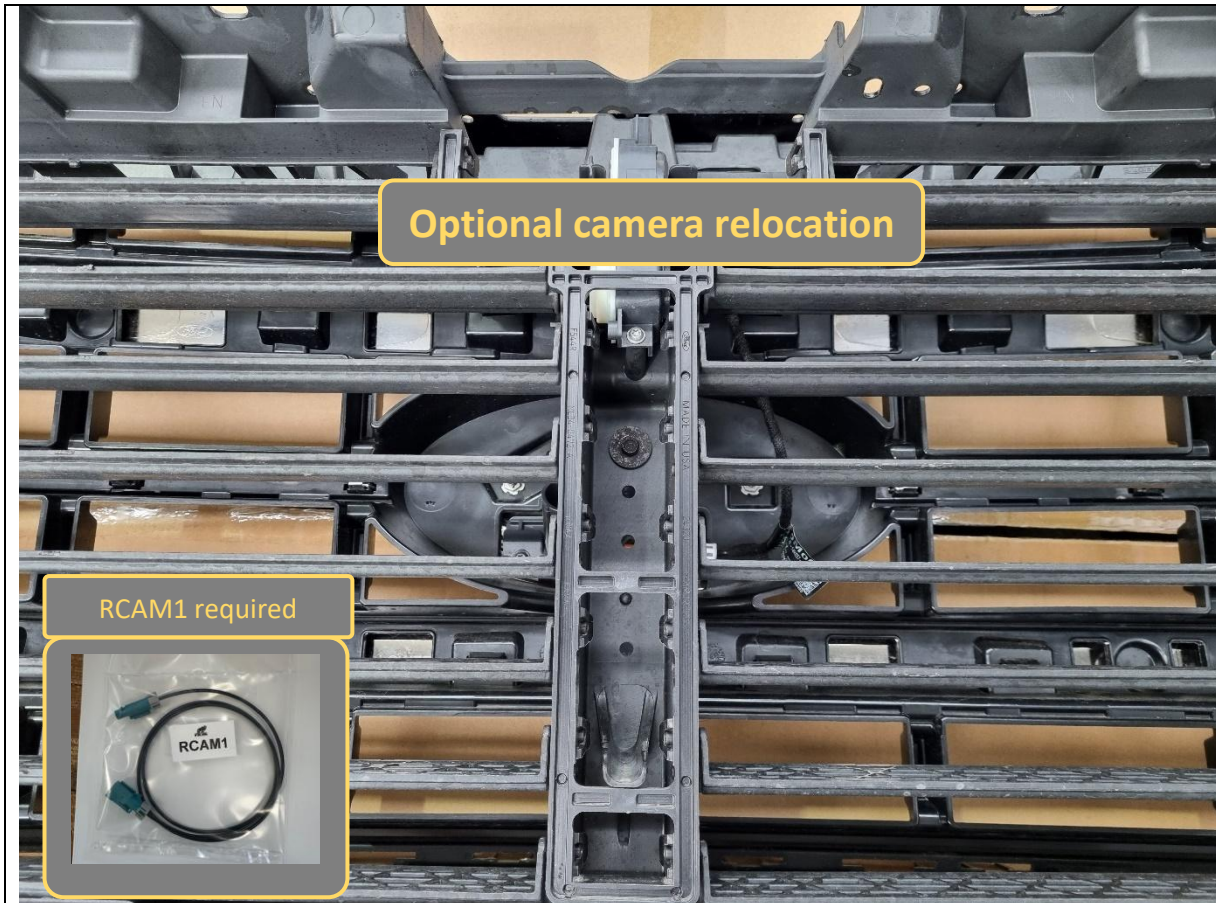

<p>64. Front 360 degree camera relocation is optional but recommended when fitting with driving lights or Offroad Animal top tube accessories (eg. Stealth Hoop or Rally Hoop).</p> <p>The Universal Camera Extension Loom (1m RF Coaxial Extension) (part no. RCAM1) must be purchased and used for this.</p>	<p>TOOLS REQUIRED</p>
<p>65. If equipped, the front camera washer nozzle cannot be relocated, it must remain in the Ford badge on the grille.</p> <p>66. Open the louvre vanes on the back of the grille.</p>	<p>FASTENERS</p>



- 67. Remove the camera from the Ford emblem by removing 3x T25 Torx screws holding the plastic camera mount bracket.
- 68. Disconnect the camera harness plug.
- 69. Take note of the camera orientation (plug should be facing the RH side of the vehicle) and set aside in a safe place.
- 70. Refit the plastic camera mount bracket to the Ford emblem, and refit the Ford emblem to the grille, if required.

TOOLS REQUIRED

T25 Torx bit

FASTENERS

3x T25 Torx screws



- 71. Fit the camera harness extension (part no. LM-FRA-NG-CAM-900) to the plug on the back of the grille.
- 72. Route the harness extension out to the bottom and front of the grille as shown.

Ensure the harness extension does not pass through any of the louvre vanes as it will get squished by the opening/closing of the louvres.

TOOLS REQUIRED

FASTENERS



73. Re-fit the grille to the vehicle and secure using fasteners removed in Step 6 and 7.

TOOLS REQUIRED

8mm socket/spanner
10mm socket/spanner

FASTENERS

2x 8mm factory hex bolts
4x 10mm factory hex bolts

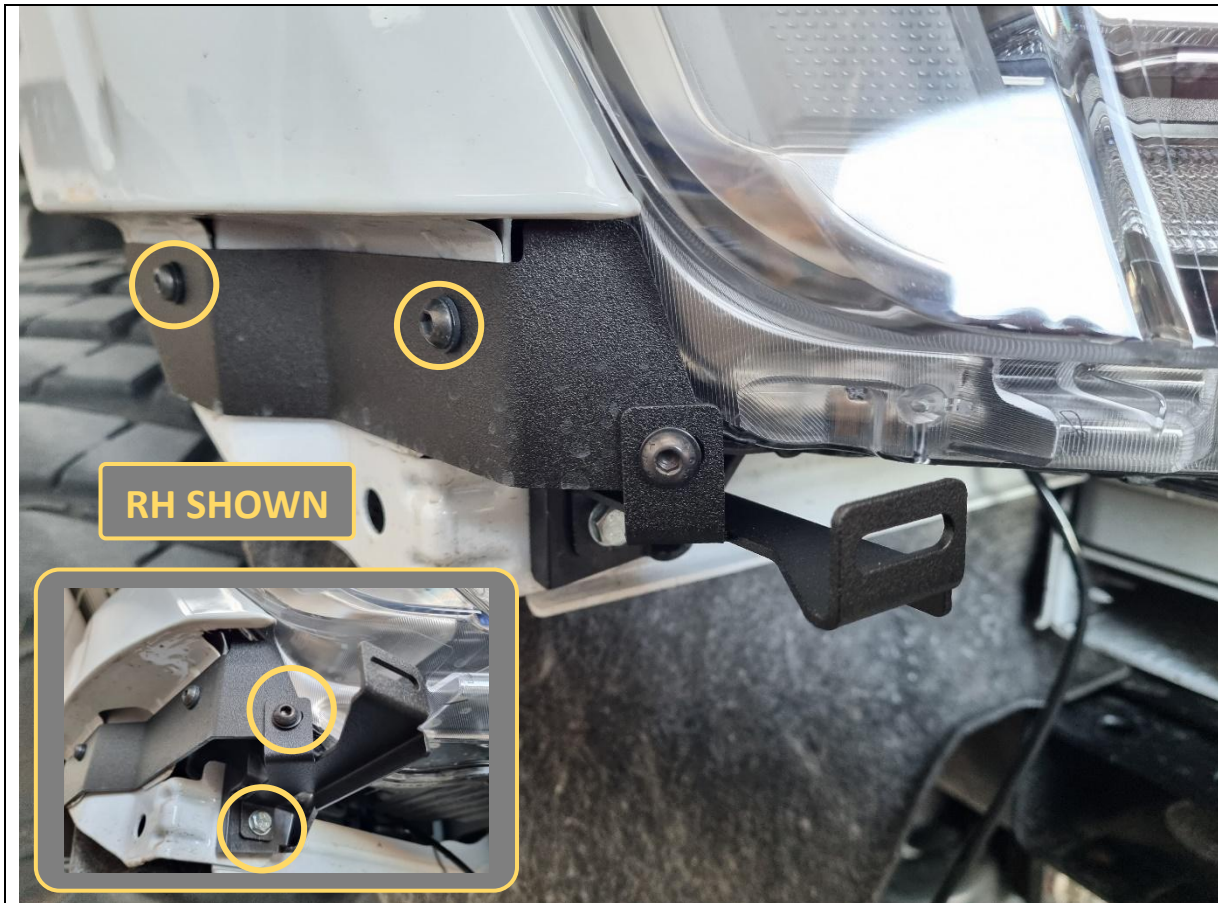

- 74. Fit the B-1118 fender guard cover plate and B-1268 plastic bumper support bracket to the vehicle, near the headlight.
- 75. Secure the fender guard cover plate with 2x M6x16 black button head bolts, black washers and flange nuts.
- 76. Secure the support bracket to the base of the headlight housing with 1x M6x20 hex bolt, black washer and flange nut.
- 77. Secure the support bracket to the fender guard cover plate with 1x M6x16 black button head bolt, black washer and flange nut.
- 78. Repeat for other side.

TOOLS REQUIRED

4mm hex/Allen key
10mm socket/spanner

FASTENERS

6x M6x16 black button head
2x M6x20 hex bolt
8x M6 black flat washer
8x M6 flange nut

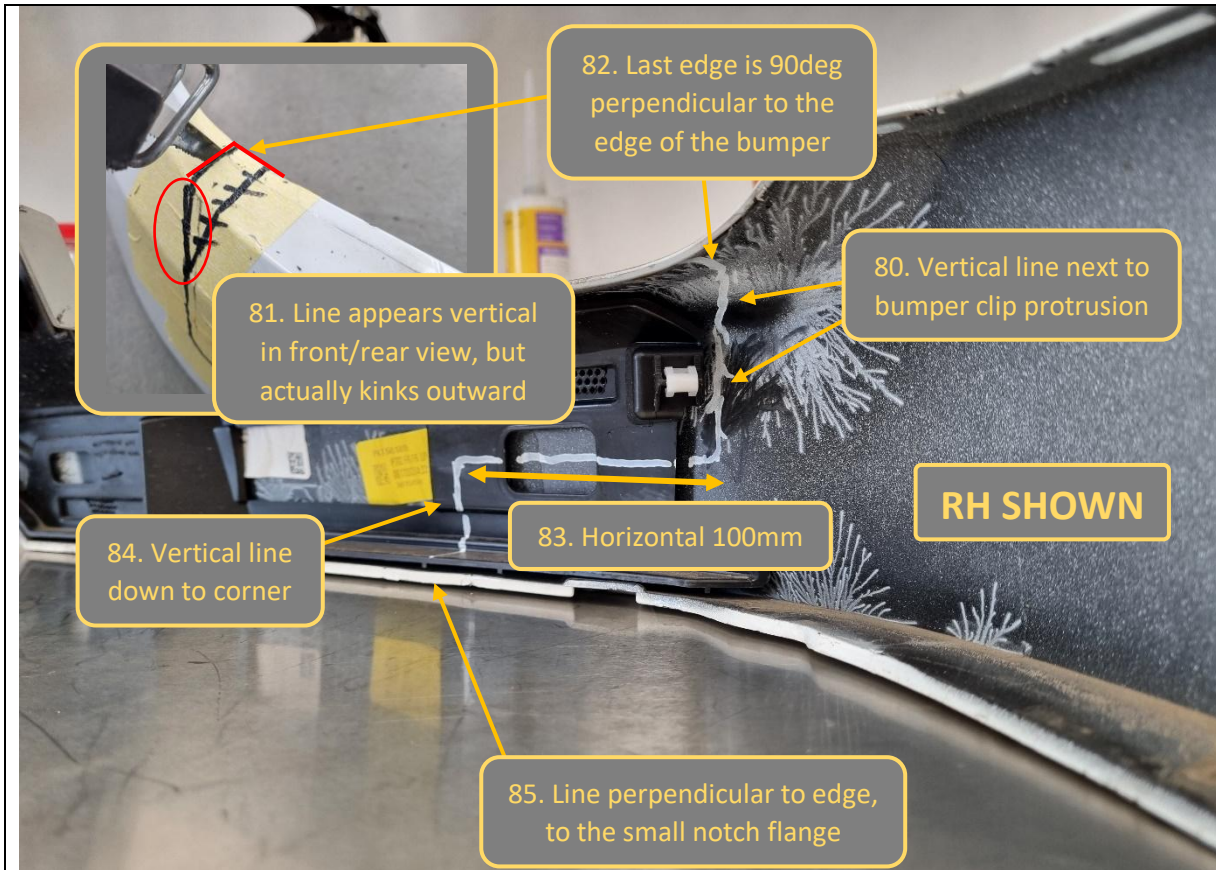

- 79. The plastic bumper removed in Step 5 needs to be trimmed. Refer to annotations above.
- 80. On the inside of the bumper, mark a vertical line next directly next to the bumper clip protrusion. Ensure this bumper clip is retained after trimming.
- 81. Extend the line upwards past the first fold line in the bumper and to to the second fold line, keeping it vertical when viewing from the front/rear as it is mounted on the vehicle. (see top left inset photo)
- 82. Extend the line to the edge of the bumper, keeping it at 90 degrees perpendicular to the edge.
- 83. Mark a 100mm long horizontal line running through the midpoint of the rectangle cuts on the inner bumper skin.
- 84. Mark a vertical line from the end of the horizontal line, down to the 90 degree corner in the bumper.
- 85. Mark a line 90 degrees perpendicular to the edge of the bumper. It should line up with the small notch as shown on the annotations.

TOOLS REQUIRED

Marker pen

2026 MARCH UPDATE

Facelift XLT models do not require the plastic bumper to be fitted. Discard it.

Facelift Lariat/Platinum plastic bumper cut shape is the same as pre-facelift shown, however some of the features on the inside of the bumper will differ slightly.

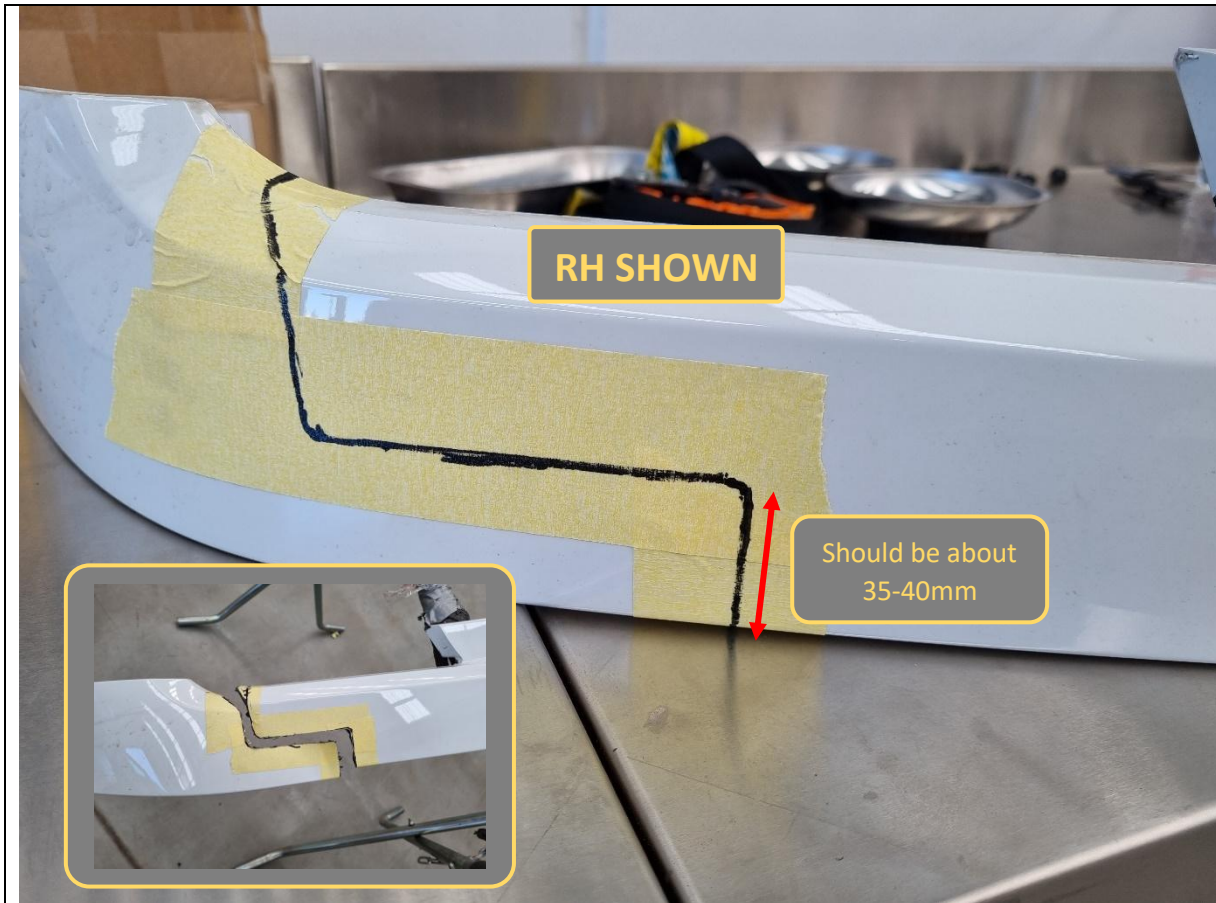

<p>86. Apply masking tape to the outside of the bumper and trace out the same cut line as the inside.</p> <p>87. Use the marked cut line on the outside as reference and cut the plastic bumper with an air hacksaw or similar cutting device.</p> <p>88. Discard the small outer section and keep the main middle section.</p> <p>89. Repeat the markings on the outer side of the bumper and cut off the end.</p>	<p>TOOLS REQUIRED</p> <p>Masking tape Marker pen</p> <p>Air hacksaw or Angle grinder or Jigsaw</p>
	<p>FASTENERS</p>

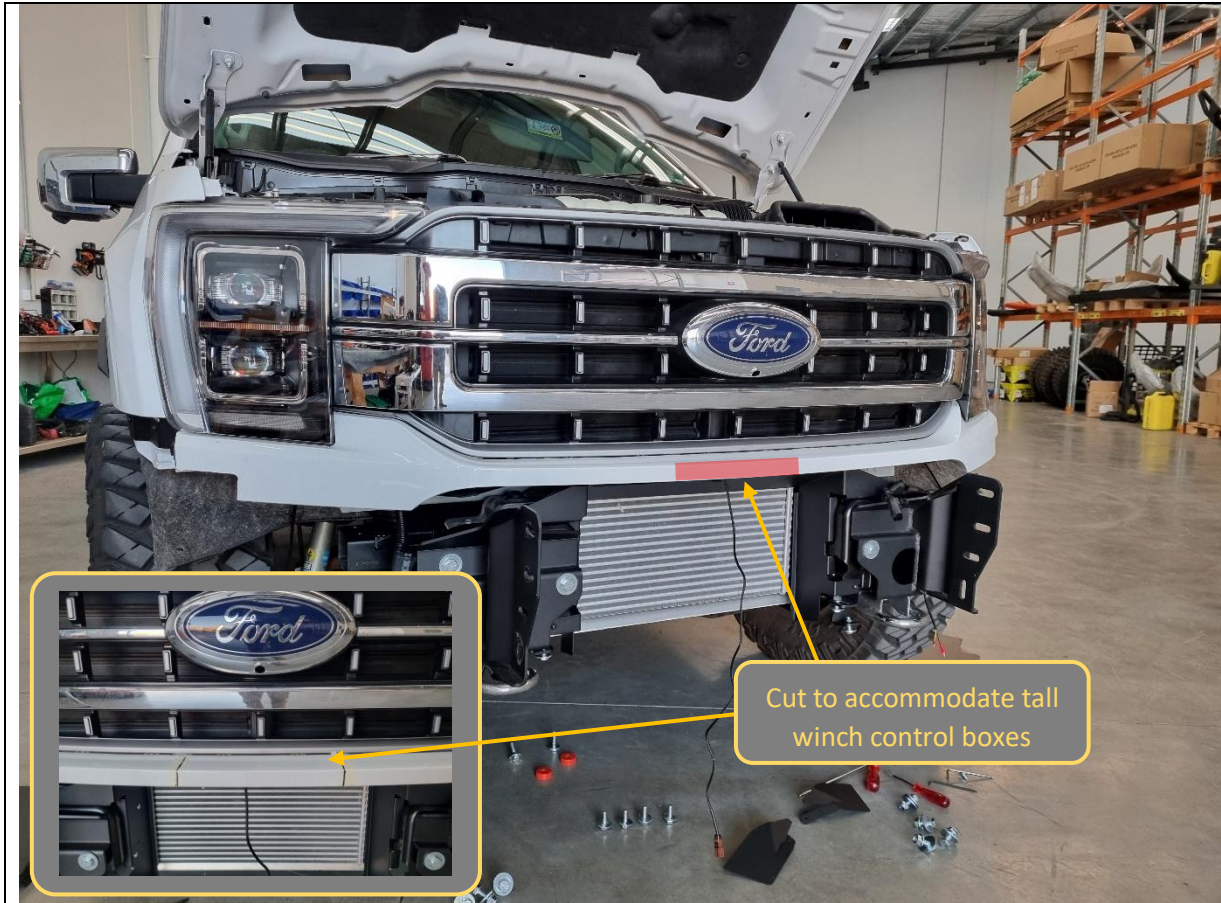

90. Re-fit the trimmed plastic bumper onto the vehicle and clip into the grille and outer support brackets installed in Steps 74-78.

91. If fitting a winch with top mount control box that is 255mm or taller (eg. WARN ZEON), you will need to cut out a notch from the bumper and grille skin as marked on the photo above. The width depends on the size of the control box. Take care not to cut the camera extension harness if installed.

WARN VR Evo winch should not need cutting if bar is fitted in the nominal correct position.

TOOLS REQUIRED

Angle grinder
or
Air hacksaw

FASTENERS

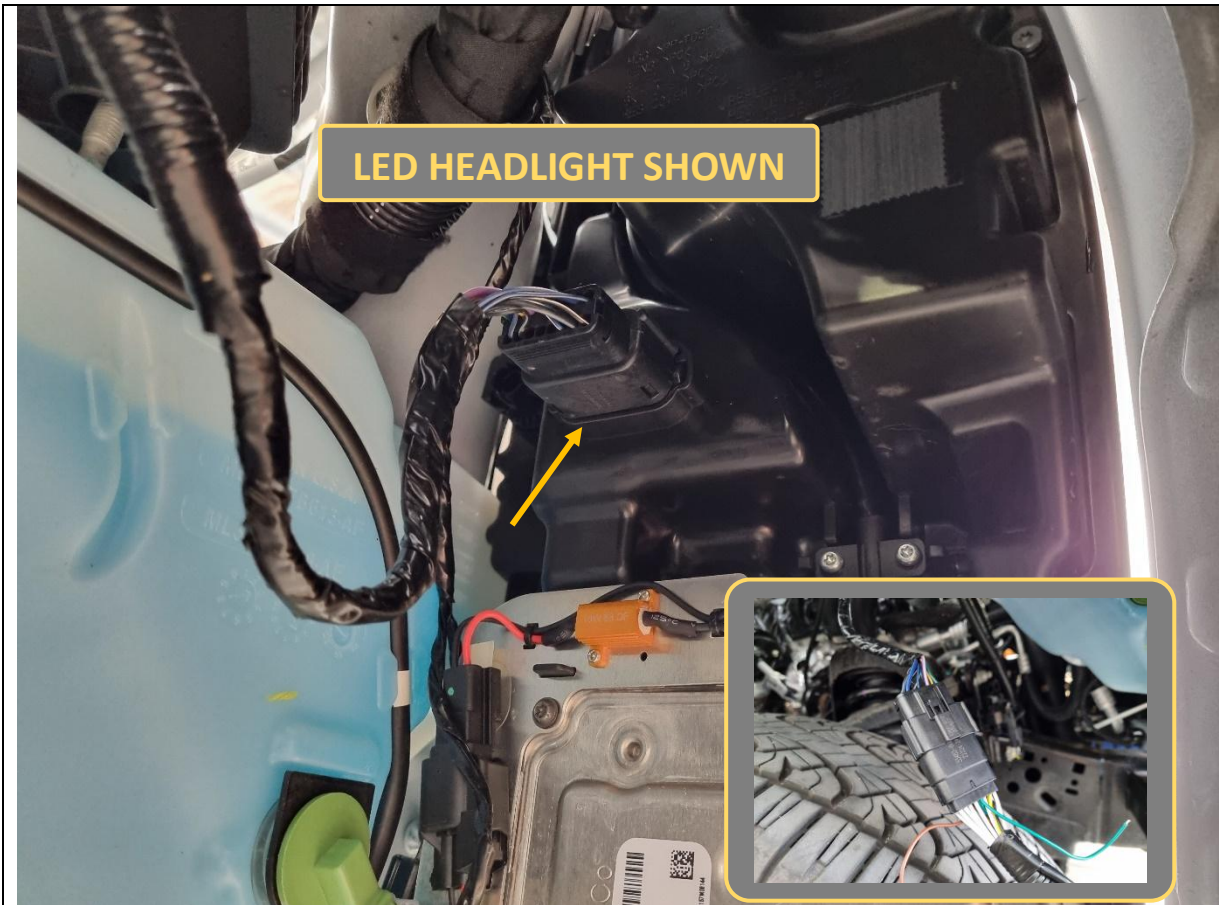

- 92. Pull back on the inner wheel arch liner to expose the back of the headlights (remove clips if required).
- 93. Unplug the main headlight connector. Image shown is for LED headlights, halogen headlight connector will look different.
- 94. If the optional indicator piggyback harness has been selected for LED headlights (eg. Lariat/Platinum trim levels), fit it to the vehicle now. Note the extra exposed wire tails on the harness do not work (Ford Ranger high beam trigger only) and need to be sealed off/insulated with heatshrink.
- 95. If not using the piggyback harness or halogen headlights are present (eg. XLT), use a test light to determine the indicator and ground wires and splice into them with automotive electrical wire. Apply appropriate electrical insulation (eg. electrical tape/conduit).
- 96. Now is also the best time to wire up high beam driving light accessories.

TOOLS REQUIRED

- Heatshrink
- Heat gun
- Solder
- Soldering iron
- Automotive electrical wire
- Electrical tape
- Electrical conduit

FASTENERS

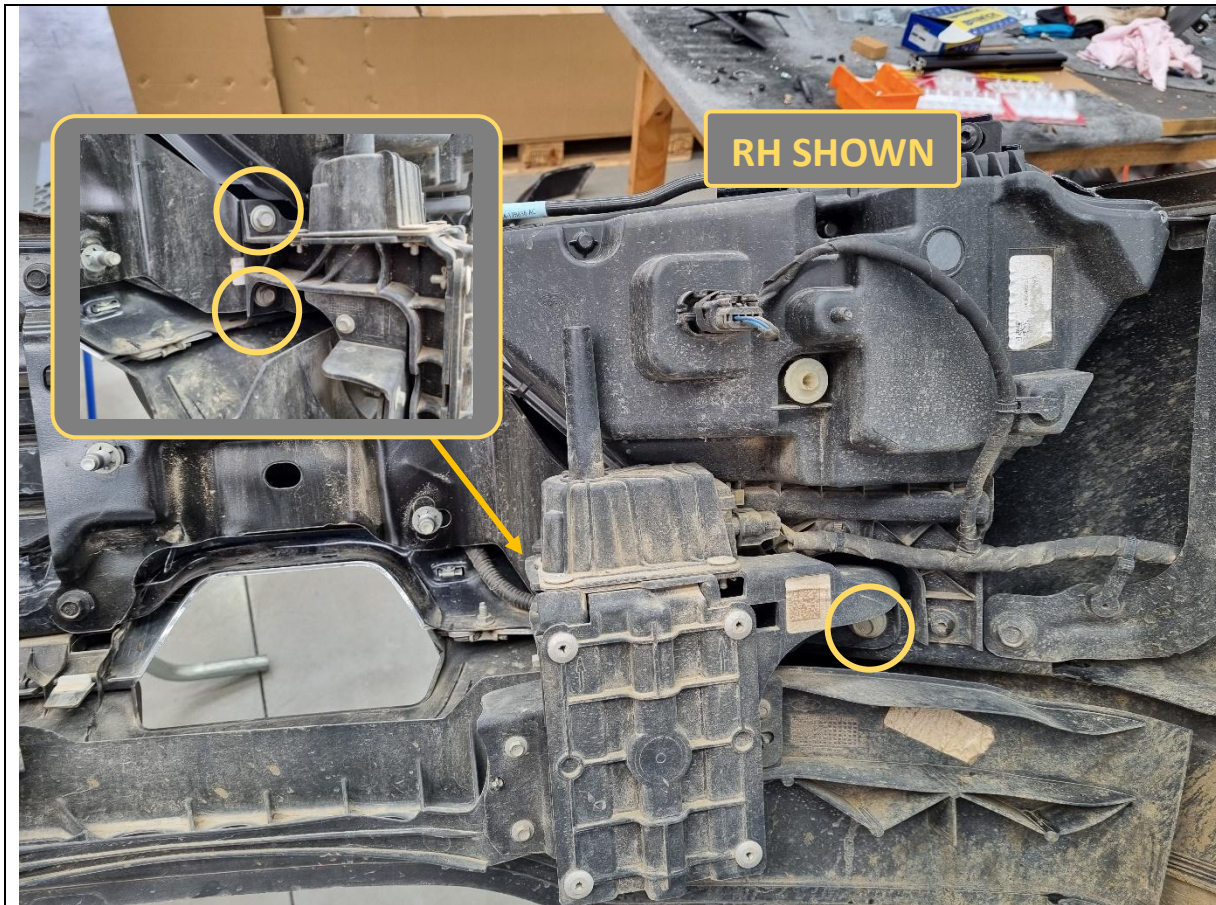

97. Prepare the bumper for stripping sensors and looms.

98. Remove 6x 13mm hex bolts securing the active air dam spoiler to the bumper. 3x bolts per side on the spoiler actuators.

TOOLS REQUIRED

13mm socket/spanner

FASTENERS

6x factory 13mm hex bolts

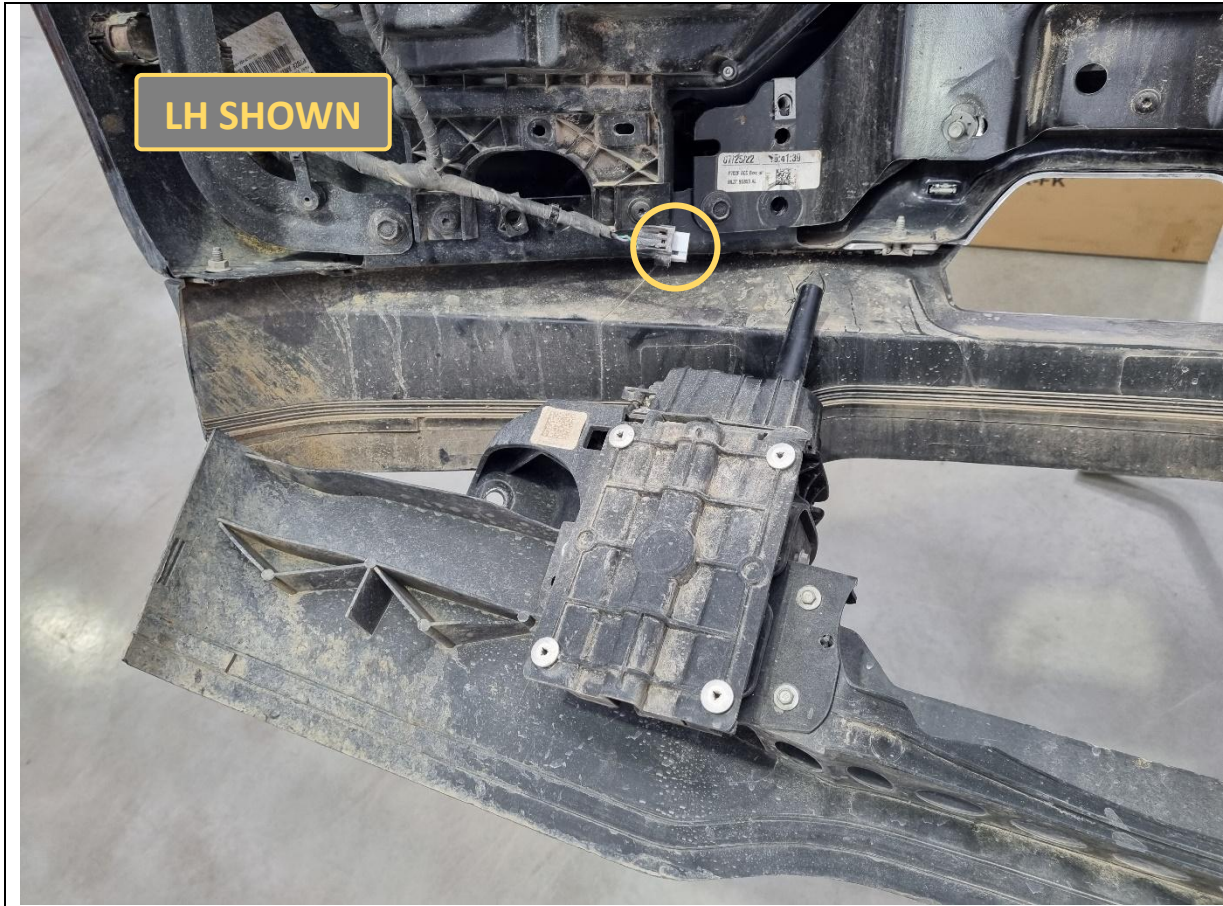

- 99. Disconnect the wiring harness plug to each spoiler actuator.
- 100. Remove the active air dam spoiler assembly. Removing the spoiler will not cause an engine management light (EML) on the dash, but may potentially leave a code on the ECU.

Offroad Animal recommends retaining the air dam spoiler assembly for a period of time (eg. 1 month) after bar installation, in case this causes issues and needs to be plugged back in. Removal of this assembly has been done and tested on multiple fitments without issue.

TOOLS REQUIRED

FASTENERS

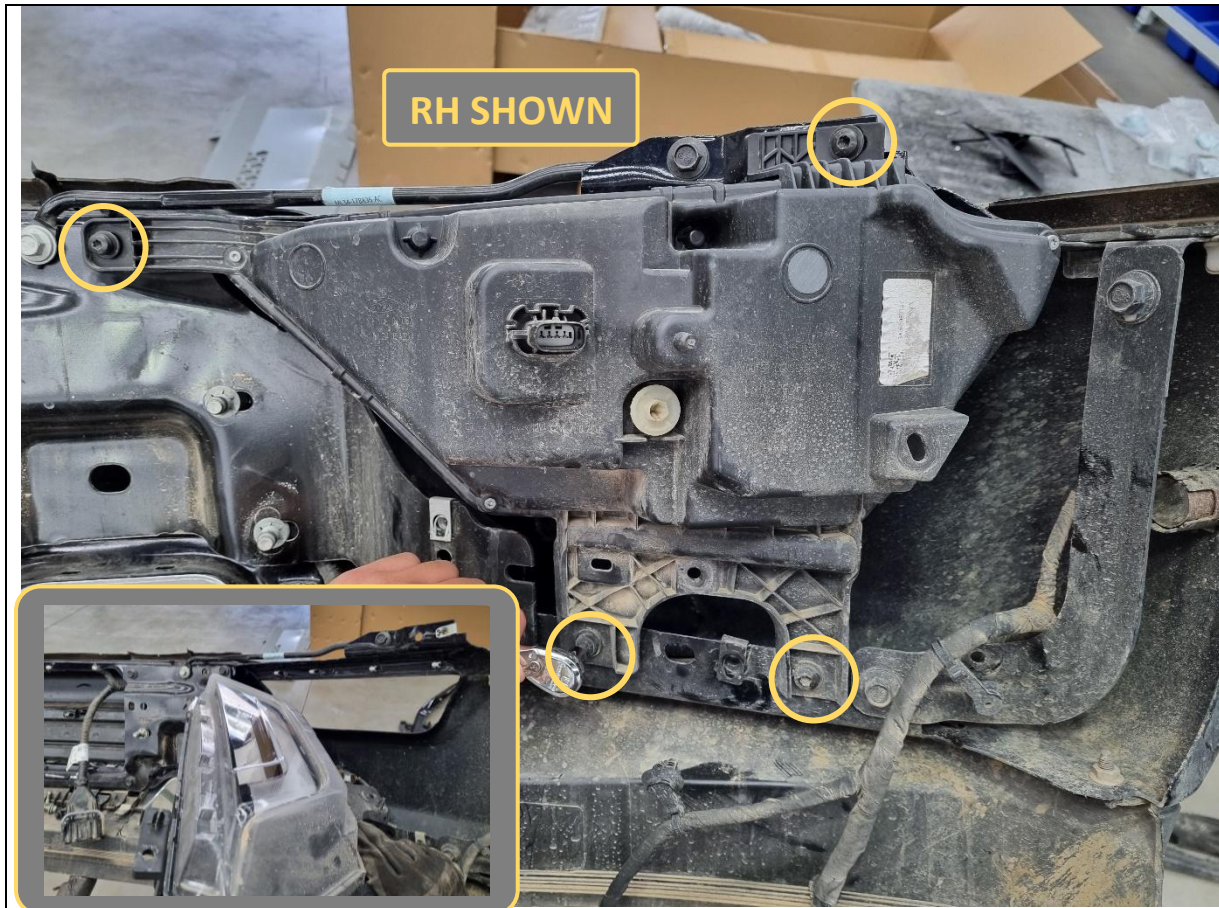

- 101. Disconnect the wiring harness plug to each fog light.
- 102. Unclip the bumper wiring harness from each fog light. Use a trim tool or flat blade screwdriver to assist.
- 103. Remove 4x T30 Torx screws securing each fog light to the bumper.
- 104. Remove both fog lights and discard.

TOOLS REQUIRED

Trim tool
or
Flat blade screwdriver

T30 Torx bit

FASTENERS

8x T30 Torx screws

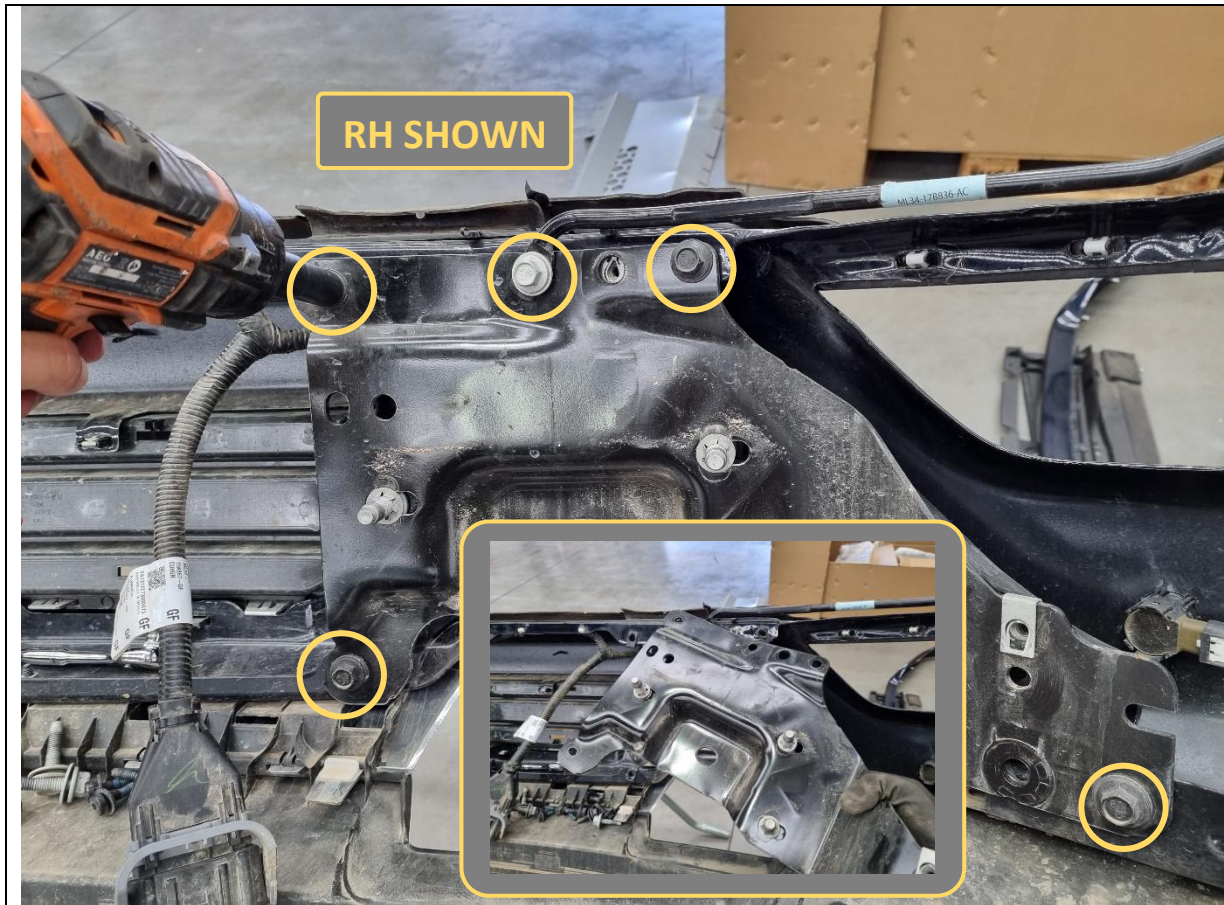

105. Remove 5x 13mm hex bolts securing the inner steel bumper bracket to the main bumper. Do this for both sides.

Do not drop the LH bracket which contains the adaptive cruise control (ACC) radar.

TOOLS REQUIRED

13mm socket/spanner

FASTENERS

10x 13mm factory hex bolts

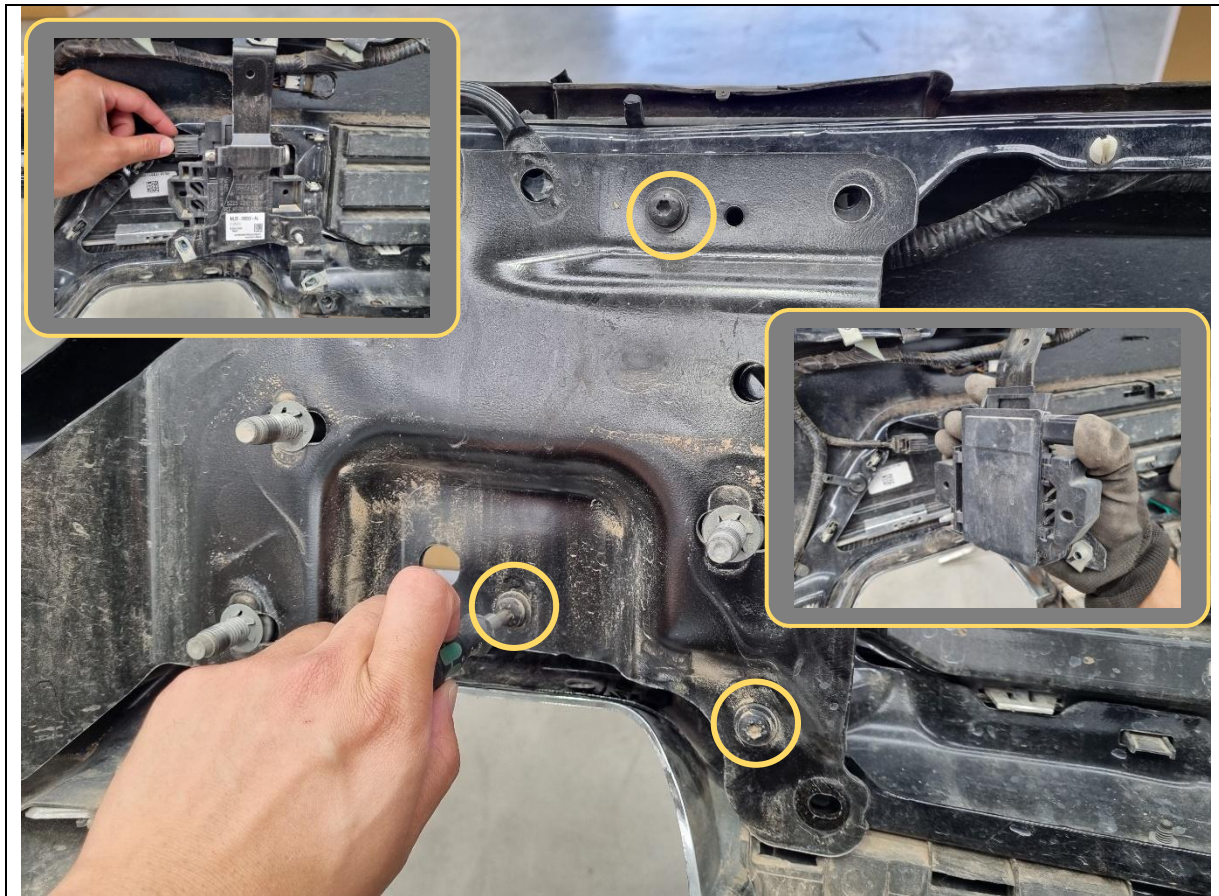

- 106. If the ACC radar is present, remove 3x T30 Torx screws securing the radar to the LH inner steel bumper bracket.
- 107. Disconnect the radar and set the radar and its mounting bracket aside in a safe place. Take care not to drop or damage the radar.

TOOLS REQUIRED

T30 Torx bit

FASTENERS

3x T30 Torx screws



108. If parking sensors are equipped, carefully pry apart the sensor holder plastic tabs to unclip each parking sensor.
109. Take note of the plug direction on each parking sensor (facing in/out). These will be re-installed into the bullbar in the same orientation.
110. Unclip the remainder of the bumper wiring harness and remove from the bumper, with parking sensors still attached. Set aside in a safe place.

TOOLS REQUIRED**FASTENERS**



111. Fit 10x M6 cage nuts into the rectangular slots on the bottom of the bar wing (5x per side).

To aid fitting, use a small flat blade screwdriver to push the edge of the cage nut to engage with the slot.

TOOLS REQUIRED

Flat blade screwdriver

FASTENERS

10x M6 cage nut



- 112. If the option has been selected, fit the Offroad Animal Halo fog lights to the supplied fog light brackets using 4x M4x12 pan head screws, flat washers and flange nuts (each).
- 113. Fit the fog light and bracket to the light mesh panel, using the supplied 2x M8x20 hex bolts, flat washers and flange nuts.

TOOLS REQUIRED

- Phillips head screwdriver
- 13mm socket/spanner

FASTENERS

- 8x M4x12 pan head
- 8x M4 flat washer
- 8x M4 flange nut

- 4x M8x20 hex bolt
- 4x M8 flat washer
- 4x M8 flange nut



114. Fit the indicator repeater lamps to the indicator brackets, using M3x12 pan head screws, washers, nuts and the adhesive backing included with the lamp module.

TOOLS REQUIRED

Phillips head screwdriver
5.5mm socket/spanner

FASTENERS

4x M3x12 pan head screw
4x M3 flat washer
4x M3 hex nut



- 115. Insert 1x M6 cage nut into the square hole in the top corner of the light mesh panel.
- 116. Fit the indicator brackets to the mesh panel, using the supplied M6 fasteners. The indicator should be located centrally in the cutout.

TOOLS REQUIRED

4mm hex/Allen Key

FASTENERS

4x M6x16 black button head
 4x M6 black washer
 4x M6 flange nut

 2x M6 cage nut



<p>117. Fit the fog light, indicator + mesh panel to the bullbar using 4x M16x16 black button head bolts, black flat washers and flange nuts.</p> <p>118. Secure and tighten using 4mm hex/Allen key and repeat for other side.</p>	<p>TOOLS REQUIRED</p> <p>4mm hex/Allen Key</p>
	<p>FASTENERS</p> <p>8x M6x16 black button head 8x M6 black washer 6x M6 flange nut</p>

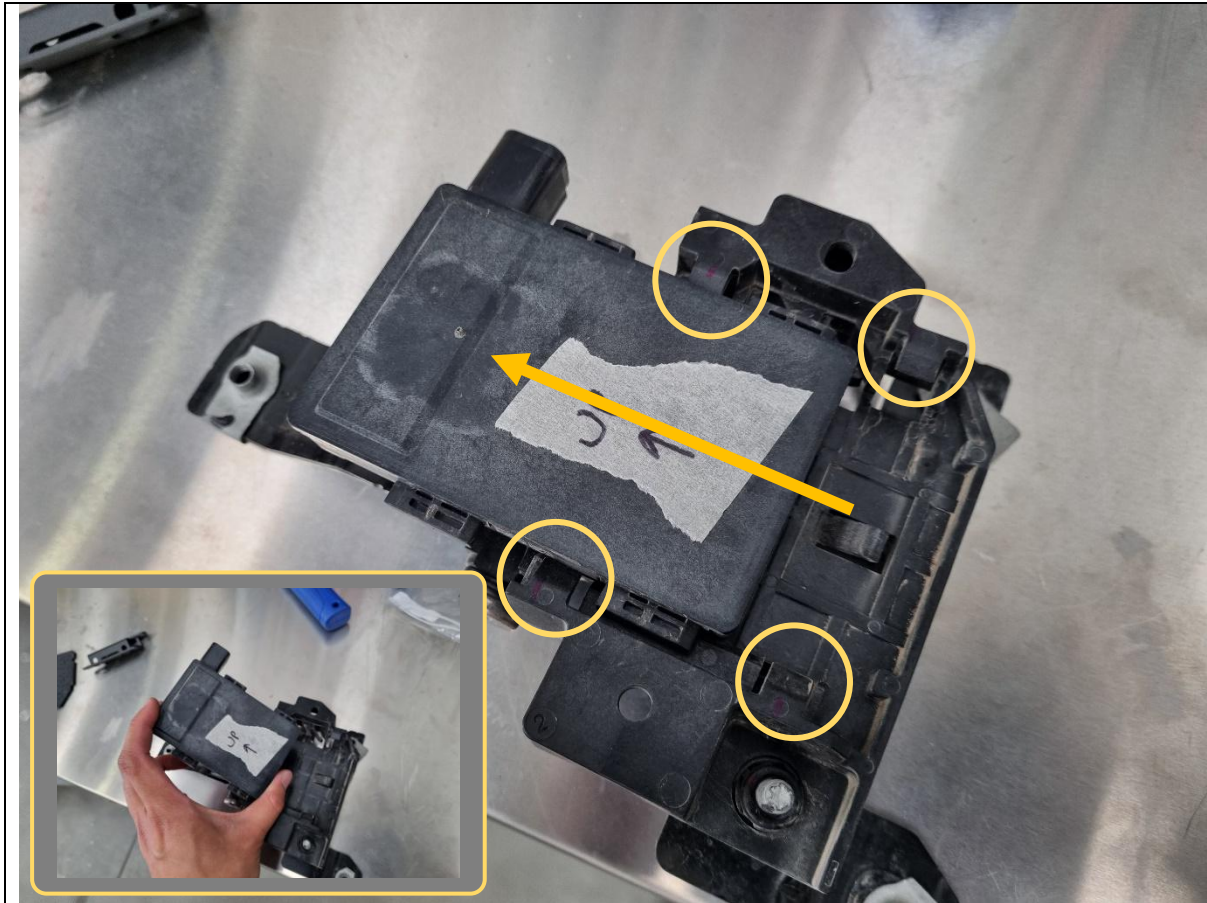

119. Release 4x tabs on the ACC radar mount and slide the ACC radar unit up and away.

TOOLS REQUIRED

FASTENERS

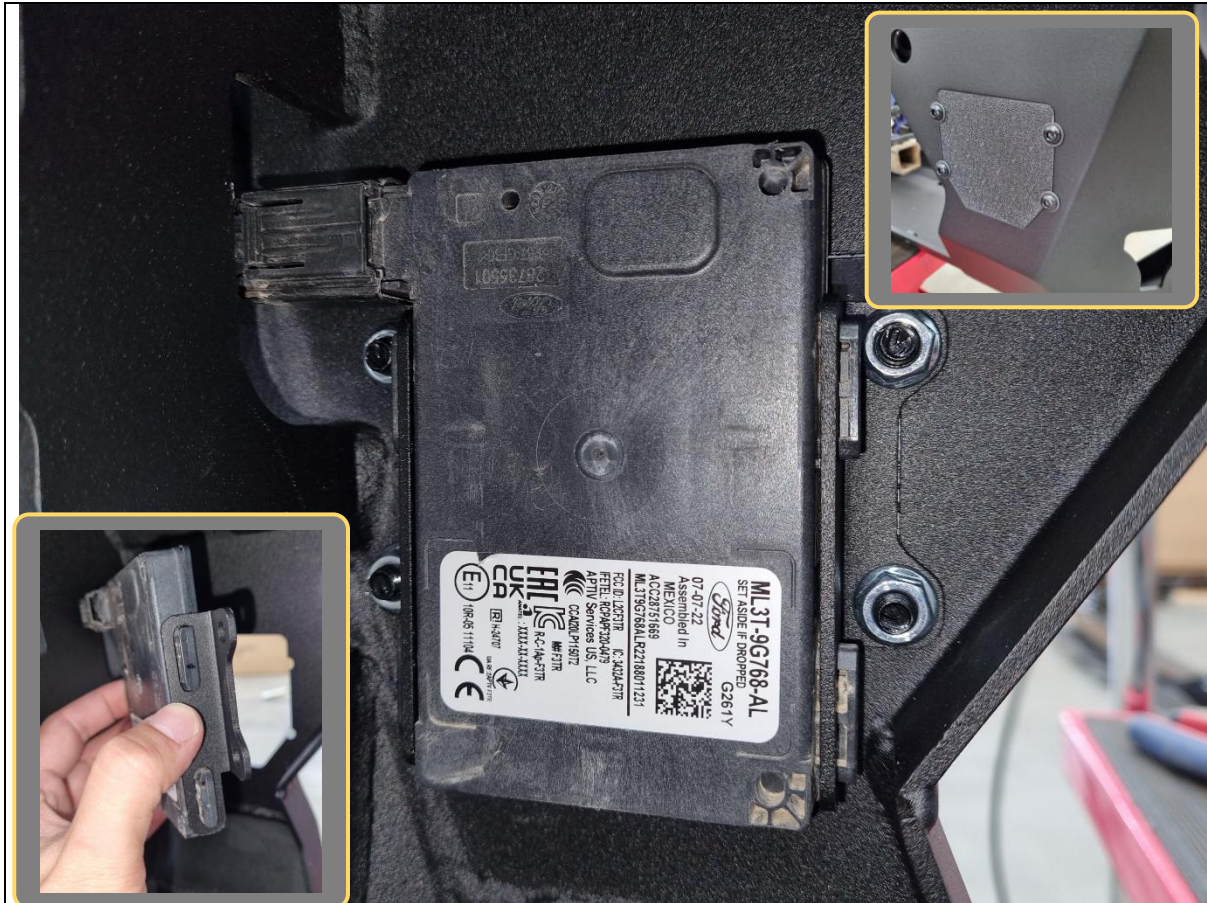

120. Fit the 2x B-1100 radar brackets onto the ACC radar unit, then hold it up against the inside of the bullbar, on the LH front face.

Note the radar plug pointing outwards through the cutout in the bullbar upright.

121. From the front face, fit the plastic ACC radar cover panel (textured face on outside) into the cutout window in the bullbar, and secure it to the radar brackets on the inside with 4x M6x16 black button head bolts, black washers and flange nuts.

122. Ensure the 2x radar brackets are tightly clamped together by hand before fully tightening M6 bolts.

123. If ACC radar is not equipped, fit the radar cover panel and brackets with no radar installed.

TOOLS REQUIRED

4mm hex/Allen key

FASTENERS

4x M6x16 black button head
4x M6 black flat washer
4x M6 flange nut

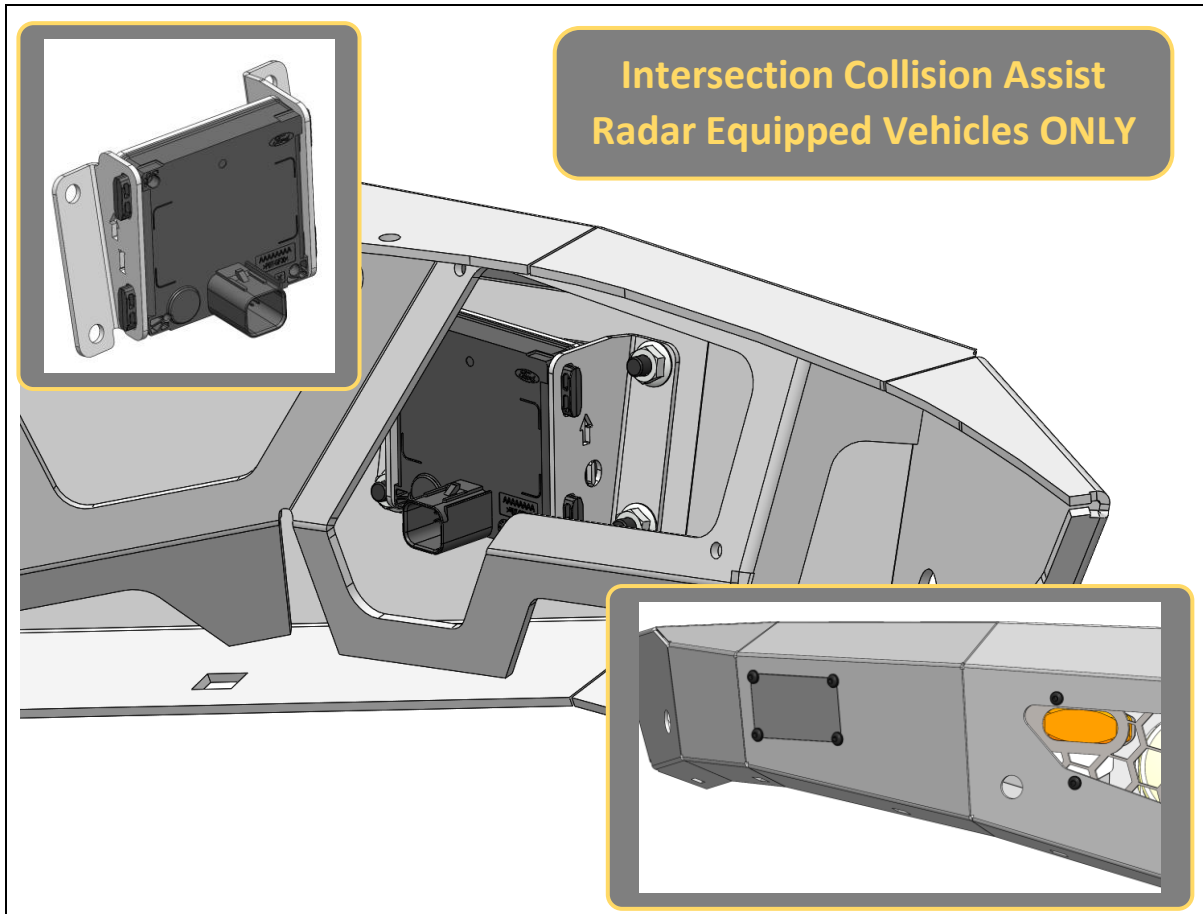

**Intersection Collision Assist
Radar Equipped Vehicles ONLY**

124. Take the ICA radar units from Step 20 and fit it to the inner and outer ICA radar clamp brackets.

Use the 'I' and 'O' markings to determine inner and outer brackets. Inner bracket is towards the inside of vehicle, outer towards the outside.

The arrow markings on the brackets should also be pointing up. Ensure the ICA radar orientation is correct and matches with the clamp brackets.
125. Hold the radar and brackets up against the inside of the bullbar, then from the front face, fit the plastic ICA radar cover panel (textured face on outside) into the cutout window in the bullbar, and secure it to the radar brackets on the inside with 4x M6x16 black button head bolts, black washers and flange nuts.
126. Ensure the 2x radar brackets are tightly clamped together by hand before fully tightening M6 bolts.
127. Repeat for other ICA radar. If no ICA radars are equipped, fit the radar cover panel and brackets with no radar installed.

TOOLS REQUIRED

4mm hex/Allen key

FASTENERS

8x M6x16 black button head
8x M6 black flat washer
8x M6 flange nut

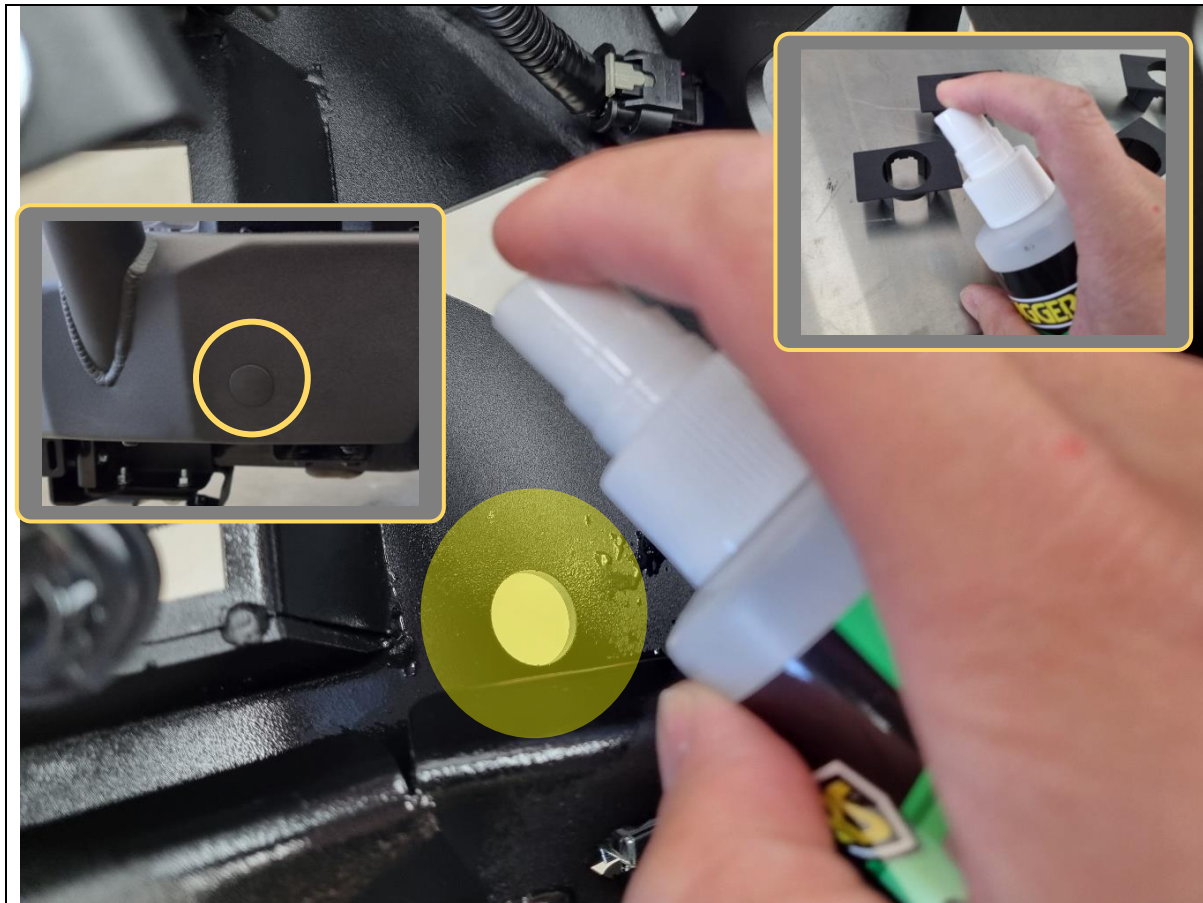

<p>128. If not fitting parking sensors, fit the supplied plastic round blanking plugs into the 6x round holes in the bullbar.</p> <p>129. If the vehicle only has 4x parking sensors, fit 2x plastic round blanking plugs to the outermost hole in bullbar on each side.</p>	<p>TOOLS REQUIRED</p> <p>Isopropyl alcohol Clean rag Sandpaper</p>
<p>130. If fitting parking sensors, clean the areas on the inside of the bullbar adjacent to the sensor holes with isopropyl alcohol. Allow to dry.</p> <p>131. Lightly scuff the bonding surfaces of the 4x supplied plastic sensor housings with sandpaper. Then clean with isopropyl alcohol or similar. Allow to dry.</p>	<p>FASTENERS</p>



<p>132. Press down on the arrow location and break the bulb of the supplied 3M Primer 94 ampule to activate the primer dispensing.</p> <p>133. Apply 3M Primer 94 to all areas adjacent to the parking sensor locations, on both the bullbar and the sensor housings.</p>	<p>TOOLS REQUIRED</p>
<p>Important: Allow at least 5 minutes for the primer to chemically bond to the surfaces.</p>	<p>FASTENERS</p>



- 134. Unplug the parking sensors from the previously removed bumper wiring harness. Take note of the location of each parking sensor on the car/bullbar (eg. outer left, middle left, middle right etc.).
- 135. Fit parking sensors into the plastic sensor housings.
- 136. Apply supplied VHB tape pads to all sensor housings as shown.

TOOLS REQUIRED

FASTENERS



<p>137. Remove backing film on VHB tape (easier with utility knife to peel off) and adhere parking sensors in position in the bullbar.</p> <p>138. Apply pressure for at least 10 seconds after positioning for best adhesion.</p>	<p>TOOLS REQUIRED</p> <p>Utility knife Automotive adhesive sealant (eg. Sikaflex)</p>
<p>Ensure the parking sensor orientation matches the original bumper. Inner 2x sensors should have plugs pointing outwards. On 4x sensor vehicles the outer 2x sensors are also pointing outwards. On 6x sensor vehicles all sensors point outwards, except for the outermost sensors on each side, which point inwards.</p> <p>139. Add a pea-sized blob of automotive adhesive sealant over the sensor holder and inside face of bar to hold to ensure the tape holds position.</p> <p>140. Route the bumper wiring harness through the cutouts inside the bullbar.</p> <p>141. Connect all parking sensors back to the wiring harness.</p>	<p>FASTENERS</p>

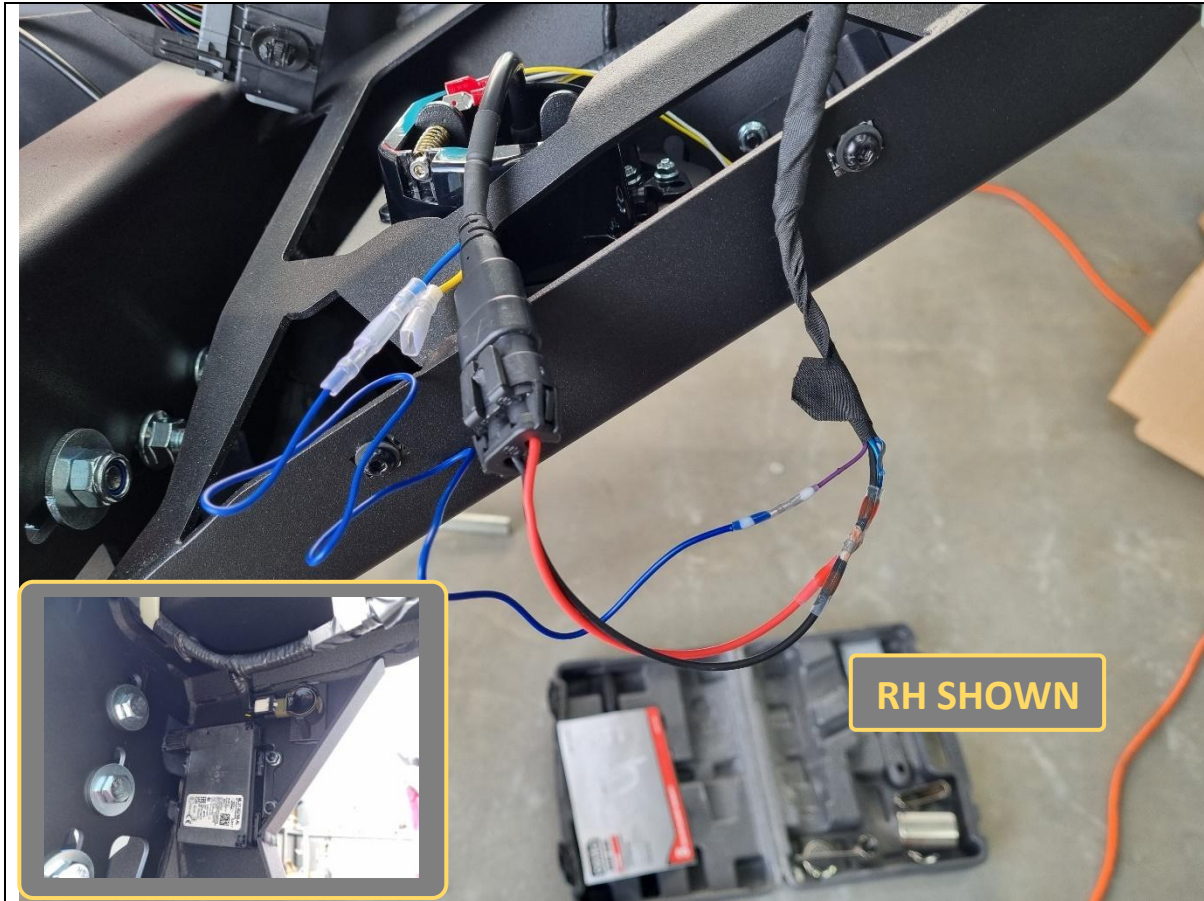

- 142. Connect all radars back to the wiring harness.
- 143. Cut off the fog light connectors on the factory bumper harness.
- 144. Determine fog light, ground and DRL (LED OE fog lights only) wires in the harness. This may need to be done with a test light after the bullbar is fitted back onto the vehicle.

TOOLS REQUIRED

- Cutting pliers
- Wire strippers
- Solder
- Soldering iron
- Heatshrink
- Heat gun
- Electrical tape

For LED OE fog lights (eg. Lariat/Platinum), the wiring pinout should be as follows:

Signal	OE harness	ORA Halo Fog
RH fog	Blue w/ green trace	Red
RH DRL	Violet	Blue
RH ground	Black w/grey trace	Black
LH Fog	Blue w/ red trace	Red
LH DRL	Grey w/ red trace	Blue
LH ground	Black w/ yellow track	Black

FASTENERS

- 145. Solder the bumper harness wires to the supplied wire tails with the Halo fog light. Use heatshrink or electrical tape to insulate them.



146. If fitting an integrated light bar, do so now.

This bar is designed to fit the Offroad Animal 32 inch light bar. If fitting this light bar, assemble the light bar with legs facing inwards, and line it up with the slots in the centre gusset. Secure with M6 fasteners supplied with the light.

This bar can accommodate most other “30-32 inch” size light bars. Stedi ST3K light bars require legs facing outwards.

147. If fitting driving lights, stealth hoop, round hoop or rally hoop to this bar, this is also the most convenient time to do so. It is still possible later but is more difficult.

148. Fit the pan brace to the back of the bar (see inset) using 5x M6x16 black button head bolts, flat washers and flange nuts.

149. Tidy up the wiring harness and other looms with cable ties on the inside of the bar.

TOOLS REQUIRED

4mm hex/Allen key

Supplied with light bar

Cable ties

Cutting pliers

FASTENERS

5x M6x16 black button head

5x M6 black flat washer

2x M6 flange nut

Supplied with light bar



- 150. If fitting antennas or other accessories on the Toro bar, fit the antenna mount bracket to the back of the Toro uprights using 2x M8x20 black button head bolts and black flat washers.
- 151. Else fit the 2x M8x20 black button head bolts and black washers to the back of each bullbar upright, to protect nut threads in bar for future use.

TOOLS REQUIRED

5mm hex/Allen key

FASTENERS

M8x20 black button head
M8 flat washer



- 152. With assistance, either from another person, or a lifting trolley, lift the bar onto the mounts on the vehicle.

- 153. Secure the bar to the mounts with 8x M12x30 Bolts, heavy duty washers and M12 Nyloc + flange nuts.

Leave finger tight at this stage.

Note: Use a washer on both bolt and nut side for the Nyloc nut. 1x washer on the bolt side is all that is required with flange nuts.

TOOLS REQUIRED

Lifting trolley

FASTENERS

8x M12x30 hex bolt
10x M12 heavy duty washer
2x M12 Nyloc nut
6x M12 flange nut

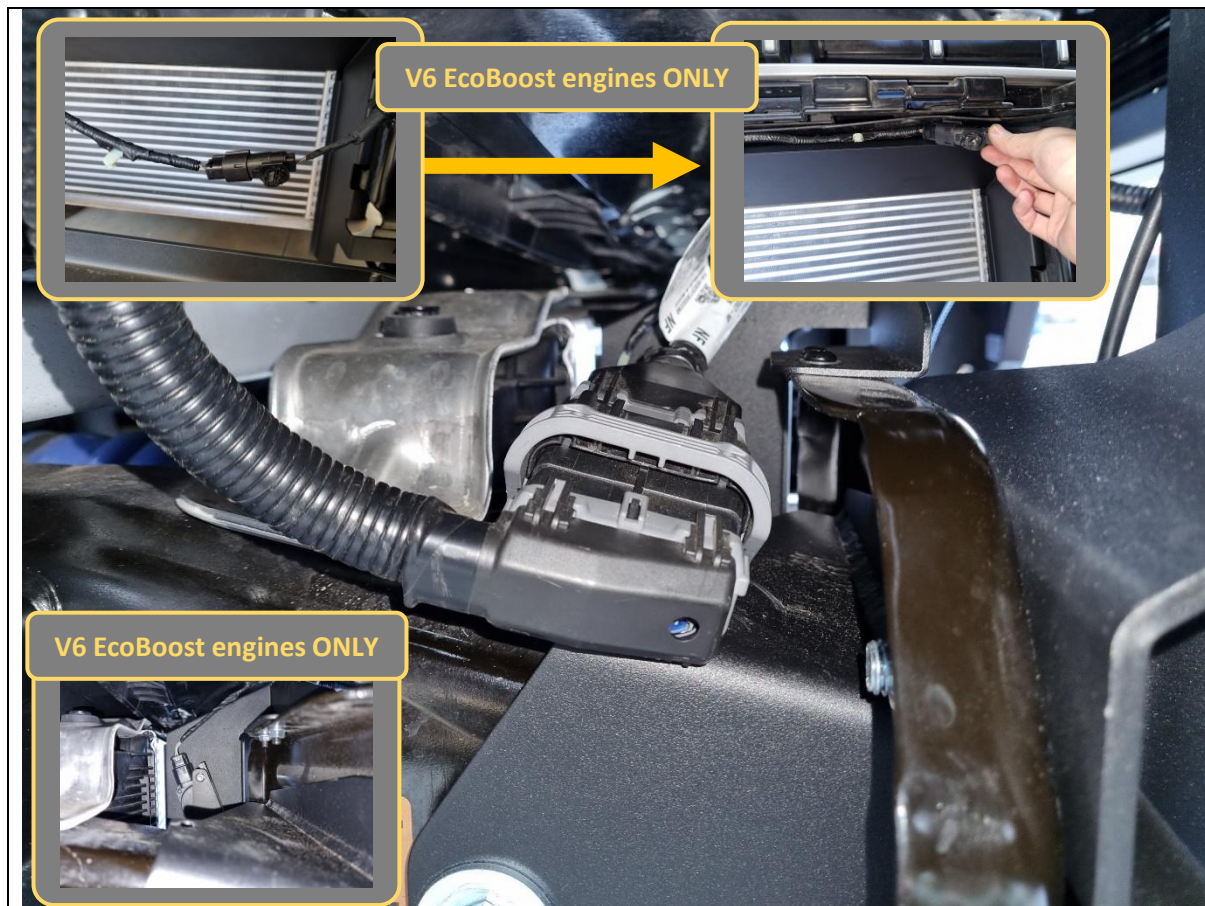

<p>154. V6 EcoBoost engine only. Re-connect the 2x intercooler shutter harnesses. One to the re-mounted shutter motor on the RH, one to the harness on the LH side.</p> <p>155. V6 EcoBoost engine only. Re-route the LH shutter harness in between the intercooler shroud and grille. (RH top inset)</p>	<p>TOOLS REQUIRED</p>
<p>156. Re-connect the main bumper harness to the body harness. Clip the harness into the slot cutout on top of the RH chassis brace.</p> <p>157. Connect the indicator/repeater lamps (solder/crimp together, ensure well insulated).</p>	<p>FASTENERS</p>

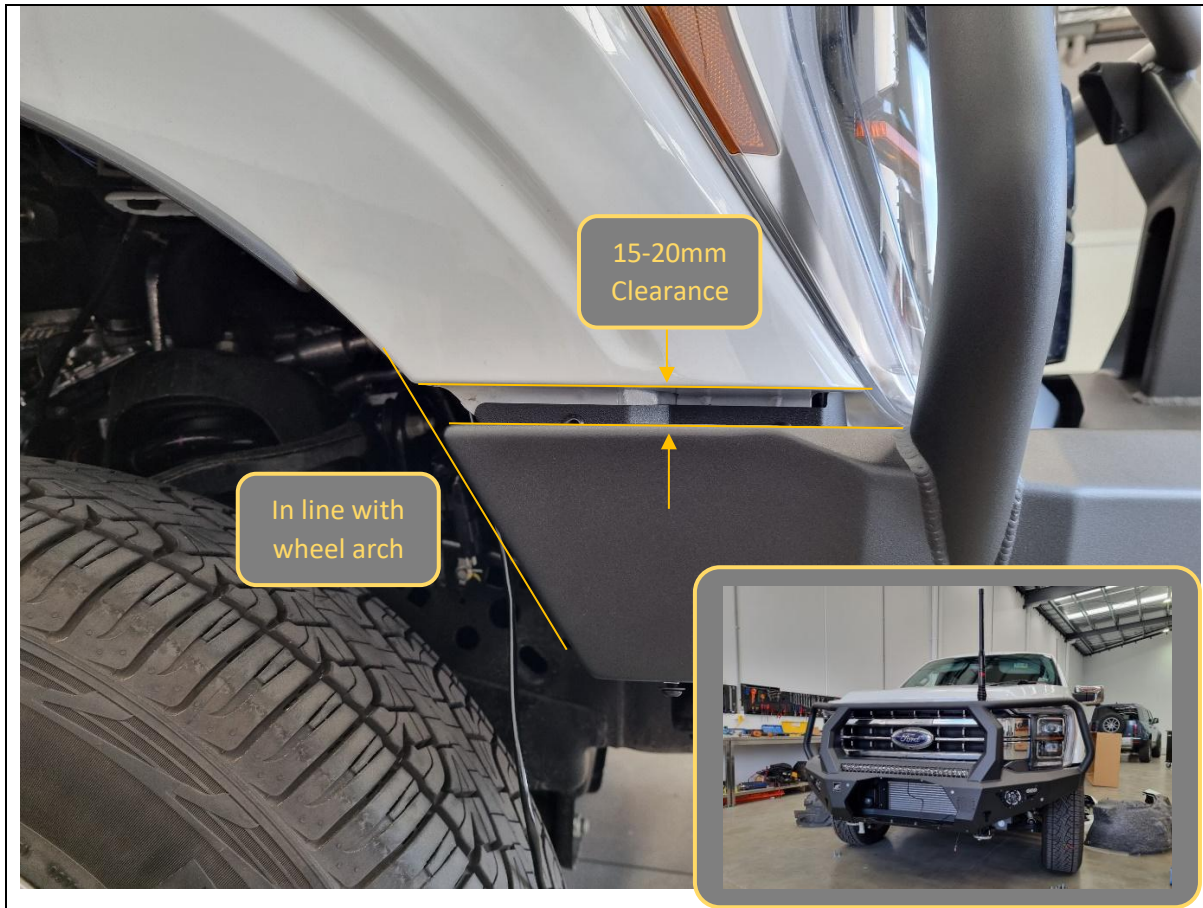

158. With assistance, from another person, align the bar with the edges of the vehicle.

In front view, the bar should sit horizontally level and symmetric left/right on the vehicle.

In side view, the end of the bar wing should be in line with the wheel arch liner. There should be 15-20mm vertical clearance between the top of the bullbar wing and the vehicle quarter panel.

In top view, there should be 15-20mm clearance between the bar and grille.

159. Once happy with alignment, tighten all 8x M12 bolts.

TOOLS REQUIRED

18/19mm socket/spanner

FASTENERS



<p>160. If fitting a winch, do so now.</p>	<p>TOOLS REQUIRED</p> <p>Refer to instructions supplied by winch</p>
<p>161. This bar is designed to fit most low mount winches, in foot down configuration. WARN ZEON 12 is the largest winch confirmed to fit (with grille cut as detailed in Step 91).</p> <p>162. Ensure clutch handle will be accessible through opening in front mesh panel. Refer to winch instructions regarding changing clutch handle location.</p>	<p>FASTENERS</p> <p>Supplied with winch</p>

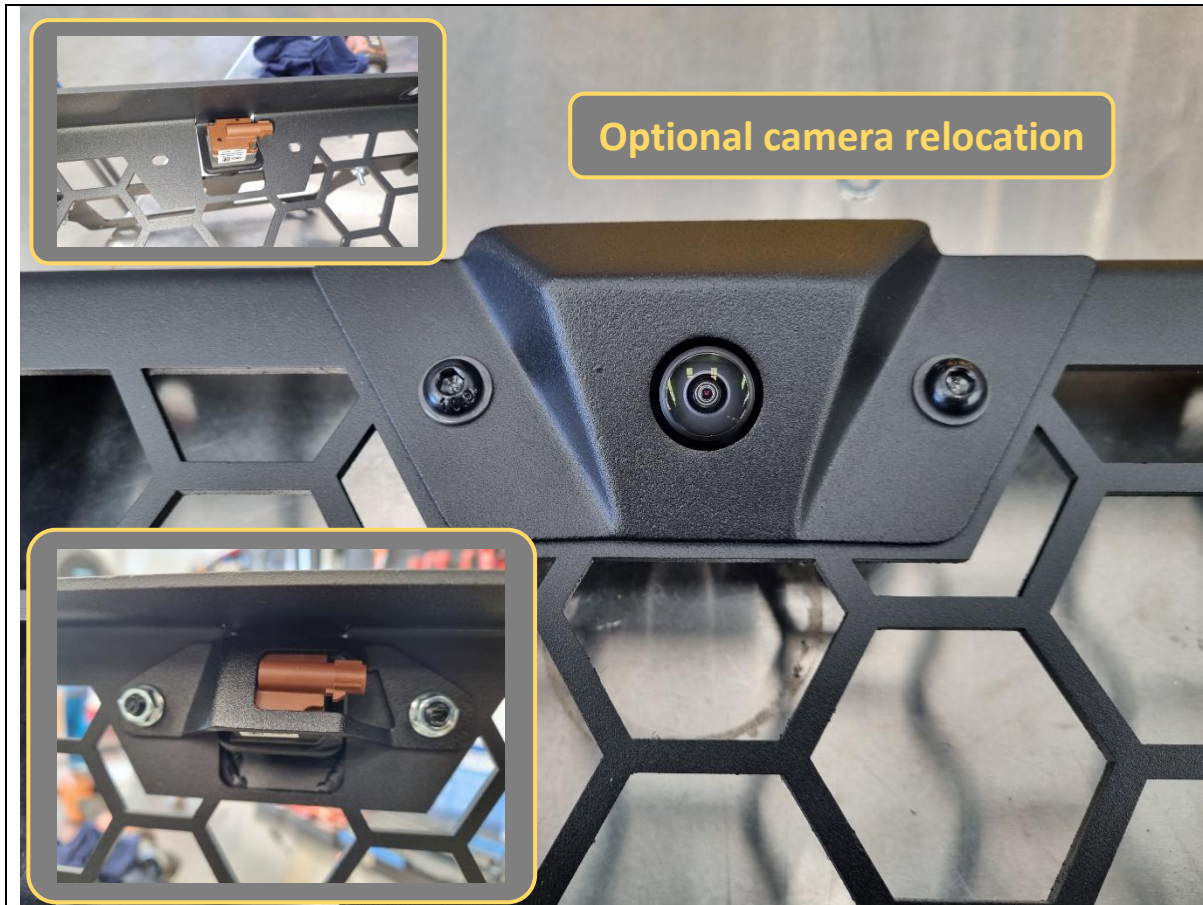

Optional camera relocation

- 163. Fit the camera to the back of the mesh fairlead, through the keyed cutout.
- 164. Fit the front camera cover on the outside, and the backing plate on the inside. The camera plug should protrude through the cutout in the backing plate.
- 165. Clamp the camera together by hand and secure the cover to the backing plate with 2x M6x16 black button head bolts, black flat washers and flange nuts.

TOOLS REQUIRED

4mm hex/Allen key

FASTENERS

2x M6x16 black button head
2x M6 black washer
2x M6 flange nut

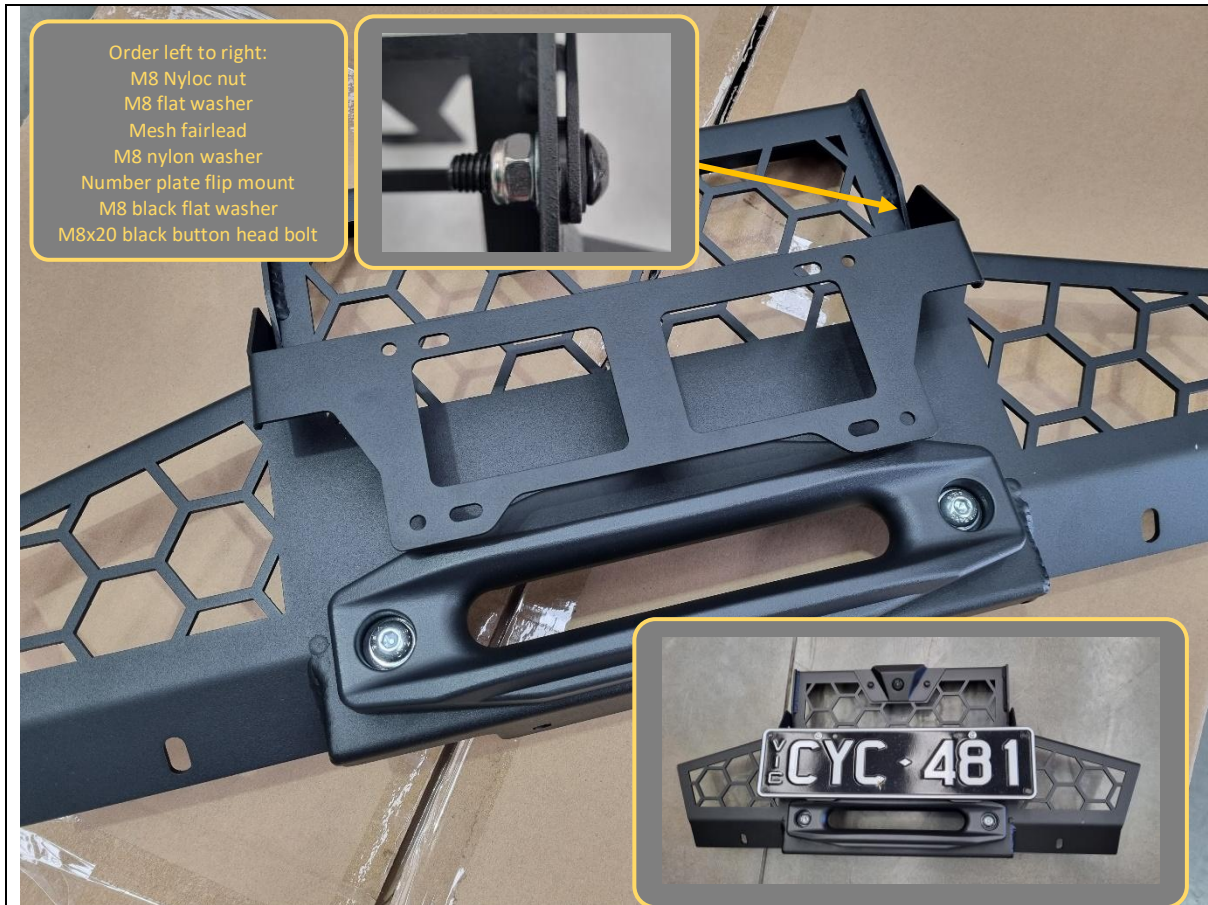

- Order left to right:
 M8 Nyloc nut
 M8 flat washer
 Mesh fairlead
 M8 nylon washer
 Number plate flip mount
 M8 black flat washer
 M8x20 black button head bolt



<p>166. If required, fit the winch fairlead to the mesh fairlead mount using M10 or 3/8" fasteners supplied with the winch. This bar is only compatible with hawse type fairleads.</p> <p>167. Fit number plate flip mount to mesh panel as shown above. Tighten bolts so that flip mount can be moved by hand with some friction resistance.</p>	<p>TOOLS REQUIRED</p> <p>5mm hex/Allen key 13mm socket/spanner</p> <p>Phillips head screwdriver</p>
<p>168. Attach number plate to mount using 2x M5x20 pan head screws, washers and flange nuts.</p>	<p>FASTENERS</p> <p>2x M8x20 black button head 2x M8 black flat washer 2x M8 nylon washer 2x M8 flat washer 2x M8 flange nut</p> <p>2x M5x20 pan head screw 2x M5 flat washer 2x M5 flange nut</p>

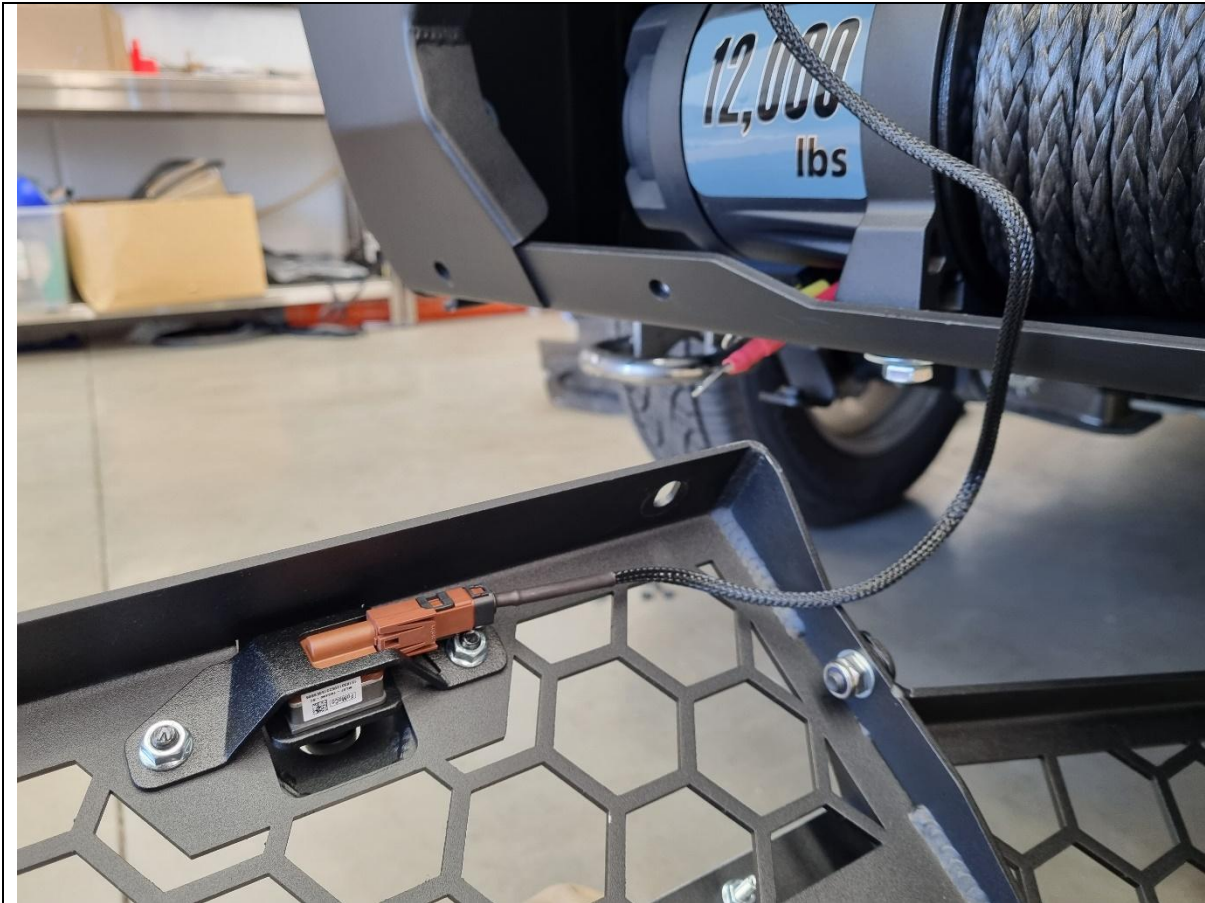

169. Present the mesh fairlead up to the bar and connect the camera to the previously installed camera extension harness.

TOOLS REQUIRED

FASTENERS



- 170. Fit the mesh fairlead mount to the centre of the bar, using 4x M8x20 hex bolts and heavy-duty washers. (2x top, 2x bottom underneath the cradle)
- 171. Access the top bolt holes from around the sides of the mesh fairlead.
- 172. Tighten fasteners using 13mm socket/spanner.
- 173. Feed winch cable through the hawse fairlead if applicable.

TOOLS REQUIRED

13mm socket/spanner

FASTENERS

4x M8x20 hex head bolt
4x M8 heavy duty washer

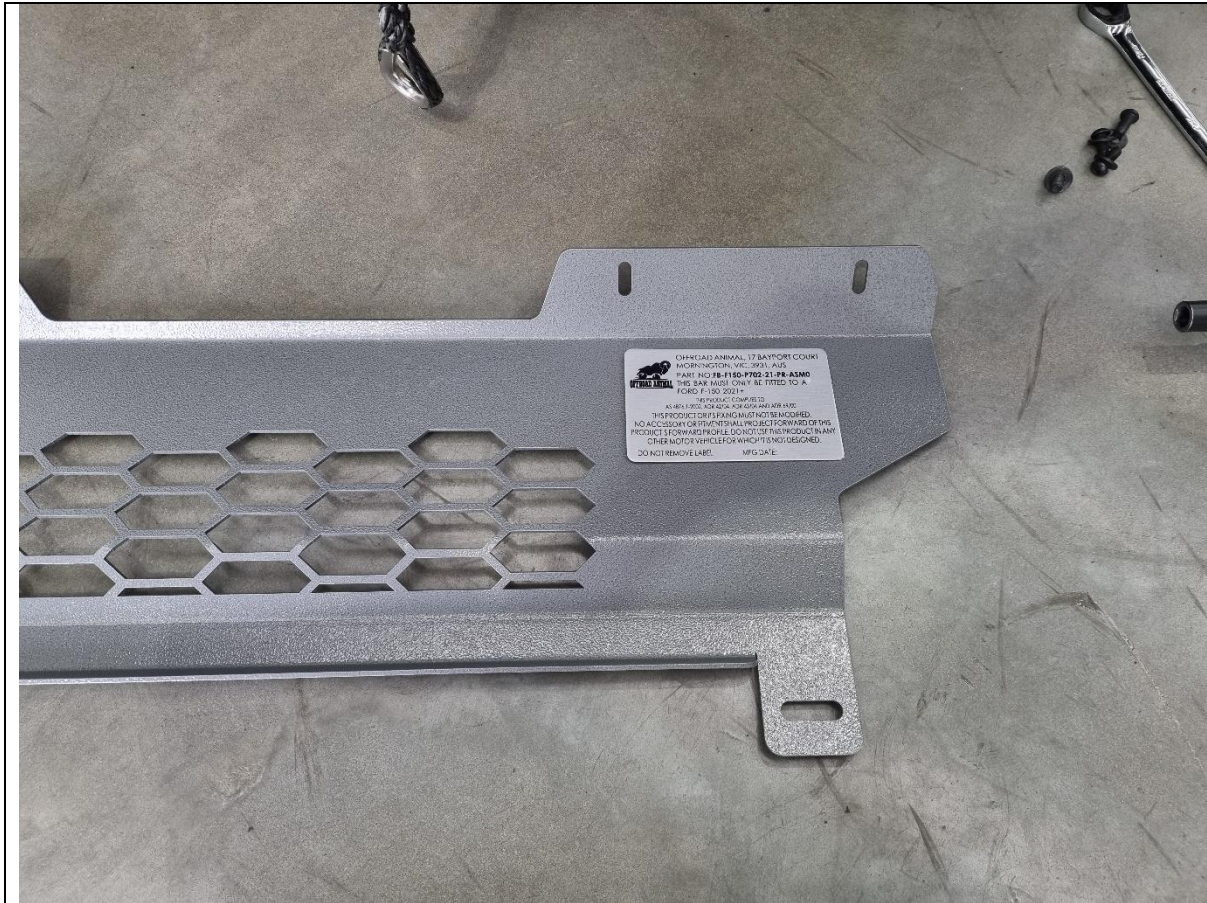

174. Fit the supplied compliance plate to the inside of the centre bash plate as shown. Peel the backing film off and adhere to the bash plate surface.

TOOLS REQUIRED

FASTENERS



- 175. Fit the centre bash plate to the bar using 4x M8x20 black button bolts and flat washers.
- 176. Secure the back of the centre bash plate to the impact assemblies using 2x M10x40 hex head bolts, heavy-duty washers and flange nuts.

TOOLS REQUIRED

- 5mm hex/Allen key
- 16/17mm socket/spanner

FASTENERS

- 4x M8x20 black button head
- 4x M8 black flat washer
- 2x M10x40 hex head bolt
- 2x M10 heavy duty washer
- 2x M10 flange nut



177. Bolt the air guide to the lower bash plate and secure using 3x M6x16 black button head bolts, black washers and flange nuts.

TOOLS REQUIRED

4mm hex/Allen key

FASTENERS

3x M6x16 black button head
3x M6 black washer
3x M6 flange nut

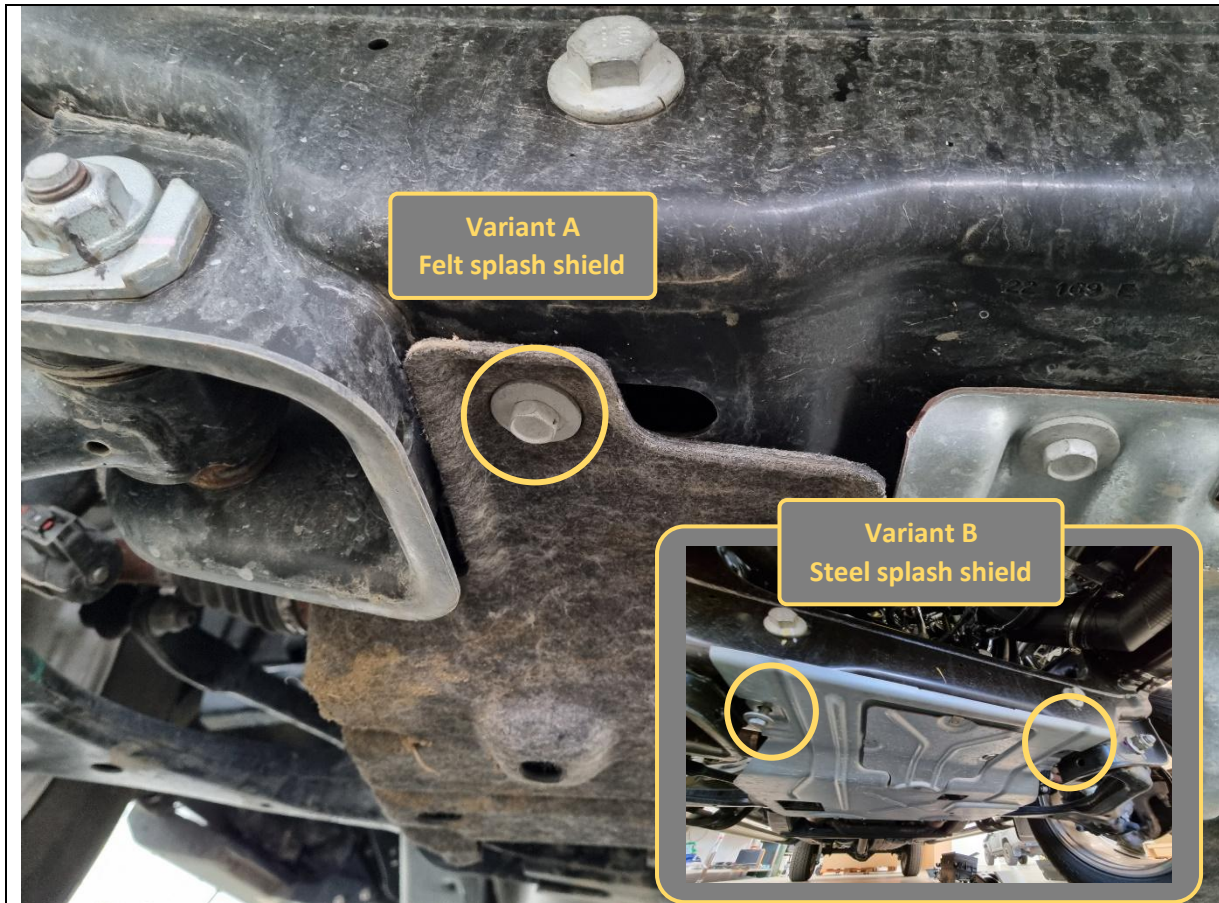

- 178. Remove the 2x front 15mm hex bolts holding the splash shield (if equipped).
- 179. Note there are two variants. If the splash shield is carpet felt, retain the fasteners. If it is steel, discard and replace with supplied fasteners, as outlined in next step.

TOOLS REQUIRED

15mm socket/spanner

FASTENERS

2x factory 15mm hex bolts

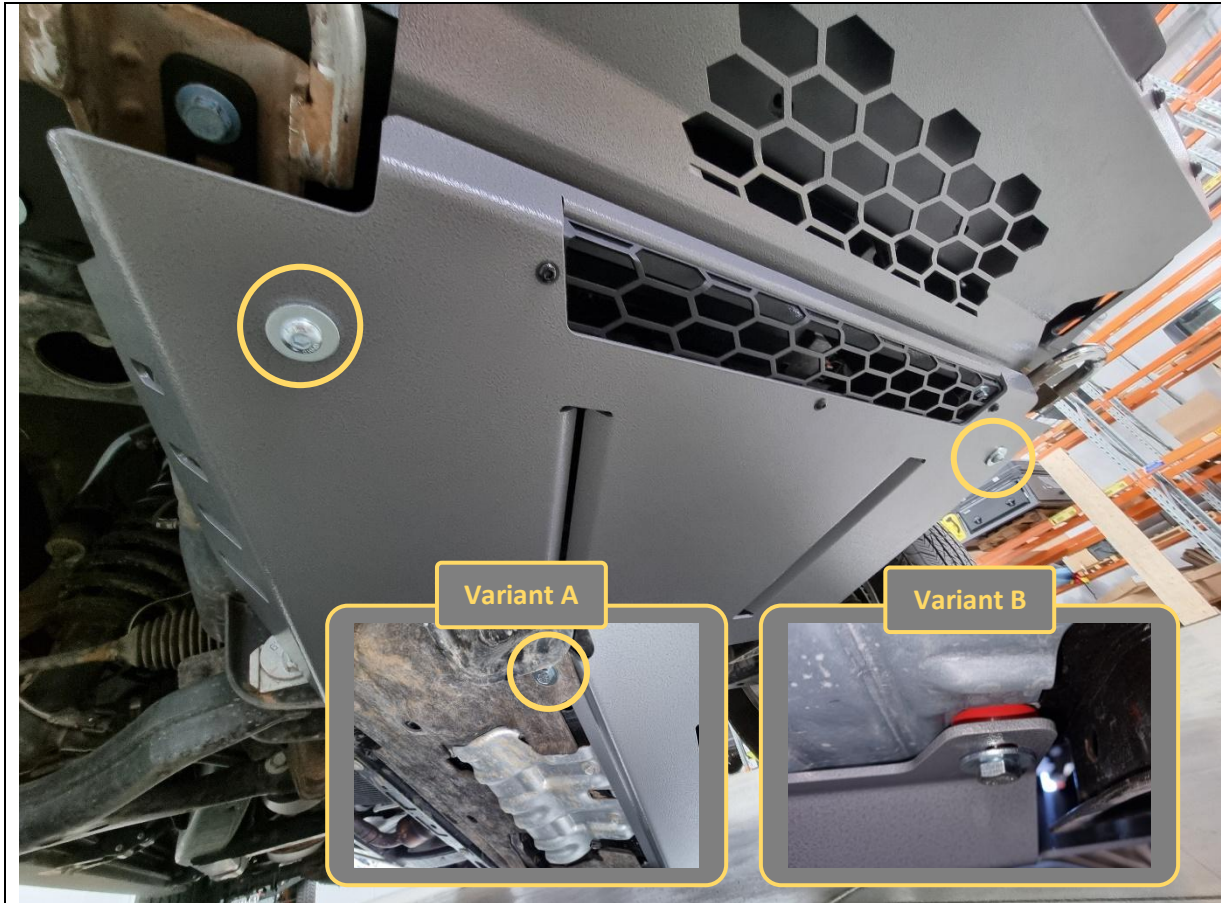

<p>180. Fit the lower bash plate. Secure the front to the lower bash plate mount weld nuts with 2x M10x30 button head bolts and heavy-duty washers.</p> <p>181. For vehicles with carpet felt splash shields, fit the rear of the lower bash plate in between the splash shield and chassis, then secure with the retained 15mm factory hex bolts.</p>	<p>TOOLS REQUIRED</p> <p>6mm hex/Allen key</p> <p>15mm socket/spanner or 16/17mm socket/spanner</p>
<p>182. For vehicles with steel or no splash shields, fit the rear of the lower bash plate on the outside, and secure with 2x M10x40 hex bolts, heavy-duty washers and P-0344 spacer block inserted between the bash plate and splash shield/chassis.</p>	<p>FASTENERS</p> <p>2x M10x30 button head bolts 2x M10 heavy duty washers</p> <p>2x factory 15mm hex bolts or 2x M10x40 hex bolts 2x M10 heavy duty washers 2x P-0344 spacer blocks</p>



<p>183. Re-fit the wheel arch liners and fold/tuck the tip in to the inside of bullbar.</p> <p>184. Secure the side underpanel to the bar with 5x M6x16 black button head bolts and black flat washers.</p>	<p>TOOLS REQUIRED</p> <p>4mm hex/Allen key</p> <p>13mm socket/spanner</p>
<p>185. Secure the side underpanel to the impact assembly using 1x M8x20 hex head bolt, flat washer and flange nut.</p> <p>186. Repeat for other side underpanel.</p>	<p>FASTENERS</p> <p>10x M6x16 black button head 10x M6 black flat washer</p> <p>2x M8x20 hex head bolt 2x M8 flat washer 2x M8 flange nut</p>



- 187. Review fitment and double check all bolts are tightened correctly.
- 188. Confirm correct operation of all indicators, fog lights, DRLs, radars and parking sensors.

TOOLS REQUIRED

FASTENERS



Congratulations! You're done!
Head out of town and enjoy your newly protected F-150!